

Geotechnical safety in relation to water pressures

B. Simpson

Arup Geotechnics, London, UK

N. Vogt

Technische Universität München, Zentrum Geotechnik, Munich, Germany

A. J. van Seters

Fugro GeoServices, The Netherlands

ABSTRACT: Provision of adequate safety in geotechnical designs dominated by water pressure has always been difficult and controversial. It is also of very great practical importance since a significant proportion of geotechnical failures is caused by the unforeseen effects of water pressure. To varying degrees, modern codes have attempted to guide rational judgments and also to provide precise formats in which safety can be prescribed. A recurrent difficulty lies in the fact that the density of water is known quite accurately, and many designers are therefore reluctant to apply factors that increase the design value of its density. Furthermore, changing the design density of water has complicated effects on the mechanics used in calculation, which may lead to unintended increases or decreases in safety.

The paper references case histories of failures caused by water pressure and reviews the safety provisions related to water pressure in some existing geotechnical codes. It discusses the provisions of Eurocode 7 and the way they are currently being interpreted and applied in individual countries. Seven examples that were discussed in the workshop on Eurocode 7 in Pavia, 2010, are considered in more detail in order to illustrate alternative approaches. The authors attempt to identify the common features of approaches to water pressure that provide a sound, rational basis for design in problems in which water pressures are a major concern.

Keywords: Geotechnical design; safety; water pressures

1 INTRODUCTION

The pressure of water in the ground and the forces exerted by free water are very important in geotechnical design. Because soil is a frictional material, its shear strength is greatly affected by pore water pressure, so increases in water pressure often reduce geotechnical resistance as well as increasing applied loads. Hence changes and uncertainties in water pressure may have large consequences that are not readily accommodated in a consistent manner by factors of safety.

Some codes of practice and design guides specify how the designer is to derive values for water pressures to be used in calculations, while others leave the question open. Advice may be qualitative, using terms such as “worst probable”, probabilistic, referring to return periods, or specified in terms of assumed margins such as tidal lags behind quay walls. Some of this guidance will be reviewed below, with particular reference to the text of Eurocode 7 (EC7). In a recent questionnaire on further development of EC7, respondents gave high priority to the need for further guidance on this topic.

Problems caused by groundwater pressures are frequently encountered in temporary states during construction. In the longer term, many cities are experiencing a rise in ground water levels, either at the water table due to leakage from supply pipes and sewers or at greater depth due to cessation of pumping from dewatered aquifers (eg Simpson et al 1987). Also water surrounding a building due to floods of adjacent rivers may cause unforeseen water pressures. The Dublin European Conference of ISSMGE in 1987 was concerned particularly with the importance of groundwater to geotechnical design. In a General Report, Stroud (1987) noted several situations in which unexpected groundwater problems have confronted engineers, in some cases leading to catastrophic failures. More recently, issues of safety in relation to water pressures have been discussed previously by Orr (2005), Simpson et al. (2009) and by Simpson (2011).

This paper is limited to considering conditions of hydrostatic water pressures or steady state seepage, in which water pressures are specified in calculations, independent of the loading and stress-strain behaviour of the ground. Situations involving the time-dependent response of the ground are not discussed.

Reference is made in this paper to “the designer”. This is taken to mean the person or people responsible for taking decisions and carrying out calculations. It may represent one individual engineer, a company, or a combination of geotechnical and structural engineers, checkers and public authorities who have to be satisfied that the design is sound.

2 CASE HISTORIES OF FAILURES CAUSED BY WATER PRESSURE

2.1 Basement excavation in Singapore

An example from Singapore, discussed by Davies (1984), is shown in Figure 1. The site was in an area of decomposed granite away from adjacent buildings and no special problems were anticipated. The basement required an excavation 8m deep which was generally carried out in open cut except locally where an anchored sheet piled wall was used to support marine clays. Excavation in the clayey decomposed granite proceeded without problems up to a depth of about 6m and was more or less dry. However, when the excavation reached about 6.5m, the southern half of the base of the excavation suddenly ‘heaved’, accompanied by a rapid increase in groundwater flow. This resulted in the base of the excavation (which up to then had been quite firm) being reduced to a slurry. Construction traffic sank into the base of the excavation and it was only possible to walk across the site on planks.

Subsequent investigations showed that a highly permeable zone existed within the decomposed granite just above rock head and water had been trapped in this zone at more or less its pre-construction pressure. When the excavation reached a depth of 6.5m, the water pressure exceeded the weight of the overburden and the excavation based heaved, increasing the permeability of the clayey soils to create vertical flow and reduce the water pressures in the permeable zone. Fortunately, in this case the consequences of the problem were not serious. However, Davies noted that Ramaswamy (1979) reports a similar case in Singapore where damage to a raft occurred due to heave as a result of high uplift water pressures being trapped in permeable laminations within a stiff clay.

This case illustrates the need to consider carefully uplifting water pressures in the ground beneath excavations, and to make allowance in design for uncertainties in the balance between water pressure and weight of ground.

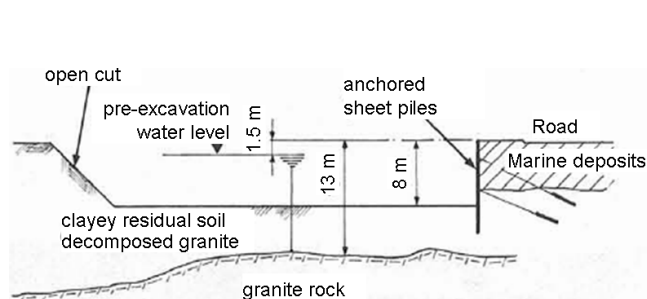

Figure 1. Section through an excavation in decomposed granite (after Davies 1984)

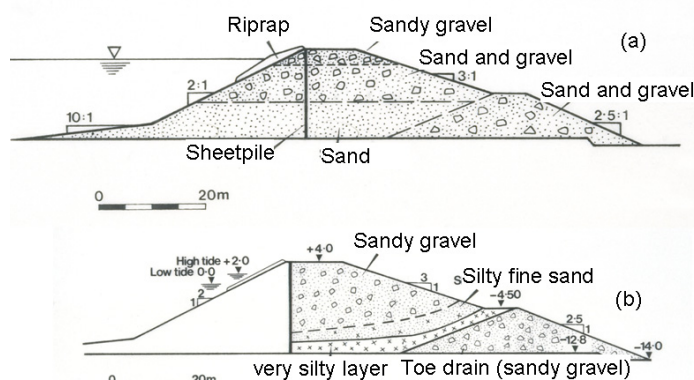

Figure 2. Cross section through cofferdam for Dubai Dry Dock: (a) as intended, (b) as built.

2.2 Earth cofferdam in Dubai

Figure 2a shows the intended cross section of a cofferdam used in the construction of the Dubai Dry Dock. The material used was the product of dredging sand and weak carbonate sandstone from the seabed. This was constructed by first forming the toe bund by dropping coarse material from bottom dump barges, then pumping hydraulic fill from cutter suction dredgers to form the rest of the bund. When the site was dewatered to allow construction of the dry dock, severe seepages were noted from the downstream slope, leading to erosion which it was feared could cause a catastrophic failure.

Small excavations were rapidly undertaken, which revealed that the as-built cross section was of the type shown in Figure 2b. Fine material deposited from the dredging had apparently proceeded ahead of

the main filling, forming a layer of low permeability over the more permeable toe bund. Trench drains were rapidly constructed, and fortunately they stabilised the situation.

This example illustrates how difficult it may be to predict water pressures in the ground in non-hydrostatic situations. It is important that designers consider a range of possibilities, dependent on the uncertain distribution of permeabilities.

2.3 Water storage basin near Stuttgart

Figure 3 shows a cross-section through a circular water basin. It was built by using pre-fabricated concrete elements connected to a cast in situ floor slab. During first filling the construction failed: several neighboured elements toppled over. The cause was seepage due to leaky gaskets leading to uplifting forces at the bottom side of the horizontal base of the L-shaped concrete elements.

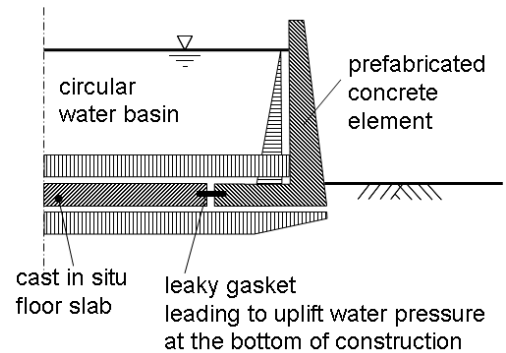

Figure 3. Water storage basin

3 EXISTING GEOTECHNICAL CODES AND GUIDANCE DOCUMENTS

3.1 UK documents

3.1.1 General

The UK documents noted here include British Standards and also guidance documents published by the Construction Industry Research and Information Organisation (CIRIA). The requirements of the UK National Annex to EC7 are considered later in the paper.

British codes specify the water pressures to be used in design calculations in a variety of ways. None of them require application of factors to water pressures.

3.1.2 BS8002(1994) – Code of Practice for Earth Retaining Structures (now obsolete)

In BS8002, partial factors (termed “mobilisation factors”) are applied to soil strengths, and no load factors are applied. The use of structural action effects derived from this code is not fully clear, however, so some structural designers apply further factors to bending moments etc derived from BS8002. Following consultations among structural engineers, Beeby and Simpson (2001) proposed that no further factors on action effects are needed for design of embedded walls designed using the prescribed overdig allowances, but in other cases calculated bending moments etc should be multiplied by 1.2.

For water pressures, BS8002 requires that “The water pressure regime used in the design should be the most onerous that is considered to be reasonably possible.”

3.1.3 BS 6349 – Maritime structures

BS6349-1 (2000) specifies (Clause 37) that “Maritime structures should be designed to withstand safely the effects of the extreme range of still water level from extreme low water ... to extreme high water ... expected during the design life of the structure. These extremes should be established in relation to the purpose of the structure and the accepted probability of occurrence ..., but should normally have a return period of not less than 50 years for permanent works.” The same clause notes “Reduced safety factors are appropriate in relation to soil pressures, mooring and berthing forces, forces from other floating objects and wave forces, when considered in conjunction with extreme water levels.”

The water levels to be assumed behind quay walls are given for specific circumstances (Clause 58). These may be related to tidal ranges, maximum changes of river levels in 24 hours, heights above flap drains, etc, as appropriate.

BS6349-3 (1988) requires a factor of safety not less than 1.2 against uplift (BS6349: Part 3: 1988, 2.5.21). Since it is not suggested that water pressures should be increased, this could be considered as a factor of 0.83 (=1/1.2) on favourable, stabilising weight.

3.1.4 CIRIA Report C580 (2003) – Embedded retaining walls: guidance for economic design

CIRIA Report C580 (Gaba et al 2003) uses a partial factor method similar to EC7 Design approach 1 Combination 2. It was written during the ENV period of EC7 and essentially supports its approach. For ULS calculations it requires that design calculations should use: “water pressure and seepage forces

which represent the most unfavourable values which could occur in extreme or accidental circumstances at each stage of the wall's construction sequence and throughout its design life. An example of an extreme or accidental event may be a burst water main in close proximity to the wall."

For SLS, CIRIA Report C580 requires that design calculations should use: "water pressures and seepage forces which represent the most unfavourable values which could occur in normal circumstances at each stage of the wall's construction sequence and throughout its design life. Extreme events such as a nearby burst water main may be excluded, unless the designer considers that such an event may reasonably occur in normal circumstances."

3.1.5 *PD6694-1(2011) – Recommendations for the design of structures subject to traffic loading to BS EN 1997-1:2004*

This BSI "Published Document" notes the alternative approaches available in EC7 (discussed below) and adds "because of the site-specific nature of uncertainty in water levels and the associated difficulties in calibration, no partial factor is given for ground-water pressure in the UK National Annex to BS EN 1990 for the design of bridges." Nevertheless, it notes: "if the hydrostatic effects are predominant and it is unrealistic to apply a significant safety margin to the water level (because, for example, the characteristic water level is close to the top of the retaining structure), it might be prudent to apply a model factor to the effect of hydrostatic pressure even when the level and density of water are known with a high degree of certainty. This model factor is required to take account of inaccurate assessment of the effects of loading, unforeseen stress distribution in the structure, construction tolerances and other secondary effects normally covered by the model factor incorporated in γ_F (see BS EN 1990:2002+A1, 6.3.2, and UK National Annex to BS EN 1990:2002+A1, Table NA.A2.4(B), Note 9, and Table NA.A2.4(C), Note 9)."

It is understood that this model factor is to be applied to structural bending moments, etc.

3.2 *German documents*

3.2.1 *DIN 1054 (2005) – Subsoil – Verification of the safety of earthworks and foundations*

This basic German standard requires that the highest and lowest water pressures that are expected during the design life of a structure have to be specified for every construction. These water pressures may be limited by the use of drainage systems or by allowing flooding of hollow constructions such as basements. Non-hydrostatic conditions and the effects of seepage have to be considered. Concerning safety factors it is possible to distinguish between persistent, transient and extremely improbable or accidental situations. As partial factors to be applied on pressures due to variable water tables those belonging to permanent actions and effects of actions may be used.

3.2.2 *DIN 4084 (draft 2002) – Subsoil – Calculation of embankment failure and overall stability of retaining structures*

In natural slopes the observational method is recommended to find water pressures. Therefore also back-analyses of critical observed situations are recommended. Water pressure in fissures in soils and rocks has to be considered.

3.2.3 *DIN 19700-10 (2004) – Dam Plants – General specifications* *DIN 19702 (1992) – Stability of Solid Structures in Water Engineering* *DIN 19712 (2007) – River Dikes*

According to these central standards to care for the protection against floods, economic, ecological, technical and aspects concerning urban developments should be considered when fixing the high-water-table for the design of dams, dikes and adjacent constructions in their design basis. Long term observations shall be analysed using statistical methods and in standard situations of urban areas a return period of 100 years shall be considered. In general multiple levels of water barriers and control systems are required. Different design situations are defined to consider also defects in one or even both of the prescribed two sealing elements. According to the probability of occurrence, different partial safety factors are defined.

3.3 *Dutch documents*

3.3.1 *NEN 6740/NEN 6702*

In the NEN-Standards for Geotechnics water pressures are mentioned. However, the value to be used for the ULS- and SLS-checks is not specified, apart from the general probability of failure.

3.3.2 CUR 166 – Guidelines on Sheet pile walls

In CUR 166, the water pressure values should preferably be determined by means of statistical analysis. Attention is given to correct distribution of the water pressures at both sides of the wall, which in case of permeable soils means that the water pressure at the tip of the wall is equal at both sides.

Based on probabilistic analyses, the water level at the active and passive sides for sheetpile design in ULS should respectively be increased by 0.05 m and lowered by 0.2 m.

3.4 AASHTO LRFD Bridge Design Specifications (2008)

The AASHTO code {10.6.3.1.1} requires that “bearing resistance shall be determined based on the highest anticipated position of groundwater level at the footing location”, but it does not apply factors to water pressures for foundation or retaining wall design, despite factoring effective earth pressures. This appears to imply that in a situation where ground water pressure is dominant the design would rely almost entirely on the resistance factors in both the ground and the structure. This issue was discussed in relation to the AASHTO code by Simpson and Hocombe (2010).

4 REQUIREMENTS OF EC7

4.1 Main text

4.1.1 Section 2 – Basis of geotechnical design

In 2.4.2(9)P, EC7 says “Actions in which ground- and free-water forces predominate shall be identified for special consideration with regard to deformations, fissuring, variable permeability and erosion.” An important note is added: “Unfavourable (or destabilising) and favourable (or stabilising) permanent actions may in some situations be considered as coming from a single source. If they are considered so, a single partial factor may be applied to the sum of these actions or to the sum of their effects.” This note raises the important issue that the various water pressures involved in a design are often physically linked and so should not have different factors applied to them, giving physically unreasonable design values.

In Eurocodes, a “design value” is a value already incorporating safety elements, being derived in most cases by factoring characteristic or representative values of parameters. In 2.4.6.1(6)P, EC7 says “When dealing with ground-water pressures for limit states with severe consequences (generally ultimate limit states), design values shall represent the most unfavourable values that could occur during the design lifetime of the structure. For limit states with less severe consequences (generally serviceability limit states), design values shall be the most unfavourable values which could occur in normal circumstances.” It is important to note that this paragraph refers directly to design values, not characteristic values, of water pressures, imposing requirements on their physical significance that may not be readily represented by processes of factoring. Despite this, paragraph 8 of the same sub-clause states “Design values of ground-water pressures may be derived either by applying partial factors to characteristic water pressures or by applying a safety margin to the characteristic water level ...”. It is apparent, therefore, that various different approaches to derivation of design values of water pressure could be used with EC7.

In 2.4.7.3.2(2), EC7 says “In some design situations, the application of partial factors to actions coming from or through the soil (such as earth or water pressures) could lead to design values which are unreasonable or even physically impossible. In these situations, the factors may be applied directly to the effects of actions derived from representative values of the actions.” This opens the possibility that allowance for the uncertainty in effects of water pressure could be made by factoring the effects, such as structural bending moments for example, rather than the water pressures themselves.

Some more detailed consideration of these requirements can be found in SC7 document N0471rev1 of June 2009.

4.1.2 UPL and HYD

Two particular situations can be identified in which water pressures are principally balanced by other loads (weight of structures or ground): uplift failure and hydraulic failure, termed UPL and HYD in EC7, as illustrated there in Figures 10.1a), 10.1e) and 10.2. EC7 provides factors of safety to be used in checking these limit states, but it is not clear about where in the calculation they should be applied. Orr (2005) noted a very large range of possible design results based on differing interpretations of the requirements for HYD.

4.1.3 Design Approaches

EC7 allows partial factors to be combined in three different ways, specified as “Design Approaches”. In Europe, each nation can elect to use one (or more) of the Design Approaches for the design of projects to be constructed on its territory. Table 1 shows the factor combinations of the three design approaches, using the default values of partial factors specified in the common version of EC7. These values can also be varied nationally, and some of the values shown in Table 1 are not supported by the present authors. The weight or pressure of water is an action.

Table 1 Default values for the partial factors in EC7. Note: the values can be varied nationally, and the values shown are not necessarily supported by the present authors.

			DA1			DA2	DA3
			Comb 1	Comb 2	Piles		
Actions	Permanent	unfav	1,35			1,35	1,35
		fav					
Soil	Variable	unfav	1,5	1,3	1,3	1,5	1,5/1,3*
	$\tan \phi'$			1,25			1,25
	Effective cohesion			1,25			1,25
	Undrained strength			1,4			1,4
	Unconfined strength				1,4		1,4
	Weight density						
Spread	Bearing					1,4	
footings	Sliding					1,1	
Driven piles	Base				1,3	1,1	
	Shaft (compression)				1,3	1,1	
	Total/combined (compression)				1,3	1,1	
	Shaft in tension		1,25		1,6	1,15	1,1

Note: Values of all other factors are 1.0. Further resistance factors are provided for other types of piles, anchors etc.

* 1.5 for structural loads; 1.3 for loads derived from the ground.

Design Approach 1 requires two separate calculations using two “combinations” of factors. The design has to accommodate both combinations. The action factors in Combination 1 of DA1 are generally applied to the actions themselves, but in some cases EC7 2.4.7.3.2(2) is followed, applying the factors to action effects. In this paper, this latter approach will be referred to as DA1*. Combination 2 of DA1 is unaffected by this.

Design Approach 2 (DA2) includes factors to be applied to actions. Originally these were to be applied to actions themselves, meaning the basic pre-defined loads acting on a structure, at the start of the equilibrium calculations and this form of DA2 is furthermore used by some countries. However, some developments, particularly in Germany, have specified that equilibrium and compatibility calculations are carried out in terms of unfactored characteristic values, applying the factors to derived action effects (such as bending moments, bearing pressures or active earth forces). This approach, called DA2*, is considered to follow EC7 2.4.7.3.2(2).

In Design Approach 3, factors are generally applied to actions, not to action effects. The calculations are performed using design values for loads and material strengths rather than characteristic values.

4.2 National annexes

4.2.1 Survey of partial factors

Partial factor values adopted for water pressures by European countries are listed in document N0467rev1 of June 2008. This information is also available on the GeoSNet website at <http://www.geoengineer.org/forum/viewtopic.php?p=11619#11619>. These documents concentrate particularly on the distinction between permanent and variable water pressures, and the notes included place important qualifications on the table of factors.

4.2.2 UK National Annex

The UK National Annex for EC7 requires the use of DA1. It notes that the normal load factors of STR and GEO “might not be appropriate for self-weight of water, ground-water pressure and other actions de-

pendent on the level of water, see 2.4.7.3.2(2). The design value of such actions may be directly assessed in accordance with 2.4.6.1(2)P and 2.4.6.1(6)P ... Alternatively, a safety margin may be applied to the characteristic water level, see 2.4.6.1(8)". This reference to 2.4.7.3.2(2) indicates that the variant DA1* of DA1 may be applicable in the case of water pressures (see 4.1.3).

Thus, by allowing three alternative approaches, the UK National Annex leaves much of the responsibility for derivation of design water pressures with the designer. For particular situations, for example along the sides of rivers, local public authorities normally specify the design water levels to be used for flood barriers and other river-side constructions.

Similar wording is repeated for the uplift case, UPL. The default values for partial factors $\gamma_{G,dst}=1.1$, $\gamma_{G,stb}=0.9$ and $\gamma_{Q,dst}=1.5$ are retained, with an added note: "The partial factor specified for permanent unfavourable actions does not account for uncertainty in the level of ground water or free water. In cases where the verification of the UPL limit state is sensitive to the level of ground water or free water, the design value of uplift due to water pressure may be directly assessed in accordance with 2.4.6.1(2)P and 2.4.6.1(6)P of BS EN 1997-1:2004. Alternatively, a safety margin may be applied to the characteristic water level, see 2.4.6.1(8) of BS EN 1997-1:2004."

For HYD, the default partial factors $\gamma_{G,dst}=1.35$, $\gamma_{G,stb}=0.9$ and $\gamma_{Q,dst}=1.5$ are retained, with an added note: "In applying the specified partial factors in Equation (2.9a) of BS EN 1997-1:2004, the hydrostatic component of the destabilizing total pore water pressure ($u_{dst;d}$) and the stabilizing total vertical stress ($\sigma_{stb;d}$) can be considered to arise from a single source ...". This implies that the same factor is applied to both stabilising and destabilising water pressures.

4.2.3 German National Annex

The German National Annex for EC7 requires the use of DA2* (see 4.1.3). It refers to a new DIN 1054 which was published in 2010 and which mostly conserves the regulations of the former DIN 1054:2005 in connection with EC7. The national values for the partial factors differ according to three different design situations: persistent, transient and accidental. As for uplift verifications the dead loads of constructions and the water pressure are well known and so it is sufficiently conservative to use the partial factors $\gamma_{G,stb}$ and $\gamma_{G,dst}$ close to 1 (0.95 to 1.05). In cases when German standards are officially introduced by German building authorities they need to be very precise and should not leave large room for adjustment by owners, designers and constructors.

4.2.4 Dutch National Annex and supplementary National Code NEN 9997-1

The Dutch National Annex, adopting Design Approach 3, combines most of the Dutch regulations of NEN 6740:2006 with EC7. For ULS and SLS verifications, the characteristic low or high values (whichever is unfavourable) for the design life of the structure based on statistical analysis must be taken.

In most cases, however, a statistical approach is not feasible because of the poor quality and limited number of the data. In practice a geo-hydrologist examines the piezometer readings over a 5 to 10 year period from neighbouring locations together with readings at the site for some months (at most). Often the maximum or minimum measured value is then taken as a characteristic high or low value, sometimes the maximum characteristic value is taken at ground level. In the Dutch code there is no guideline/rule for determination of the characteristic value of the groundwater table. Normally the water table is taken as a constant corresponding with the highest/lowest value. Fluctuations of water levels are therefore not considered as a transient load.

For water pressures in STR/GEO-limit state a load factor of 1.2 is taken where a higher water level is physically not possible. In other, seldom used cases, a load factor of 1.35 is applied. Alternatively, in case of retaining structures the characteristic water table at the low, excavated side must be lowered by an offset of 0.25 m to derive at a design value.

For Uplift (UPL) and Hydraulic actions (HYD), partial factors for $\gamma_{G,stb}$ and $\gamma_{G,dst}$ of respectively 0.9 and 1.0 are prescribed. This means that the factors on water pressure are 1.0 in these cases. The Dutch standard must be followed by designers and constructors, but alternative methods are possible as long as the required safety level is proven!

5 SOME FUNDAMENTAL CONSIDERATIONS

5.1 *Primary and secondary actions*

Even in cases where the magnitudes of the primary actions are fixed with no possibility of unfavourable variations, designs should be sufficiently robust to accommodate unknown and unpredictable secondary actions. In the cases considered in this paper, the primary unfavourable actions are derived from water pressure, which in some cases may have very clear limits. Secondary actions could include, for example, sedimentation around a structure in water, excavation of the ground above a structure relying on the weight of ground, minor vehicle or ship impacts, considered too small to include in calculations, or vandalism of various kinds.

If these “secondary” actions are large, failure could occur but the fault may be seen to rest with the owners or maintainers of the structure, or the vandals; alternatively, the designer should have foreseen them and was wrong to omit them from the primary actions for which the structure was designed.

However, if the secondary actions are small, the owner would reasonably expect the structure to be sufficiently robust to withstand them. In this context, “large” and “small” effects have to be judged in relation to the magnitude of the primary actions. It follows that even where there is no real possibility of unfavourable variation of the primary actions, it may be necessary to include some variation of them in design in order to accommodate the possible secondary actions that are not otherwise included. The variations could be applied either to the actions themselves, in deriving design values, or to the action effects.

5.2 *Compatibility with structural codes*

It is very desirable that geotechnical and structural codes of practice can be used together in a compatible way. This is a basic principle of the Eurocodes and other sets of codes. Many structural codes include partial factors on actions that take the magnitudes of the actions to unrealistic levels. In part, this may be a way of accommodating secondary actions, and it creates no difficulties in most aspects of structural design.

In geotechnical design, two related features are very important: (a) water pressure may be a dominant action, determined by the density of water which is accurately known, and (b) because soil is a frictional material, its shear strength is greatly affected by water pressure. Unrealistic factoring of water pressure therefore raises concerns.

These issues underlie the discussions in this paper.

5.3 *Water retaining structures*

Some of the examples considered in this paper involve water retaining structures. The release of a large body of fluid may create an unusually dangerous situation, so structures retaining free water might have to be considered as high risk, requiring better standards of design checking, construction and maintenance. Higher factors of safety might also be considered, though they could give false confidence. This issue is not the subject of discussion in this paper.

6 EXAMPLES

6.1 *General*

SC7 document N0471rev1 provided six examples which had been developed to illustrate particular issues in relation to water pressures. Under the auspices of ISSMGE ETC10, a Workshop on EC7 was held in Pavia, Italy, in April 2010, three of these were briefly discussed among other design examples (Simpson 2011). Some of these design situations will be discussed in more detail in this section.

6.2 *Example 1 – Submerged anchor block*

Figure 4a shows an anchor block, for which the total weight W is a permanent stabilising (favourable) force and the anchor force F is a variable destabilising (unfavourable) force. The characteristic total density of the block is γ_c and that of the water γ_w . The water forces are taken to be permanent.

The strength of the ground or structure are not at issue, so the only ultimate limit state to be considered for the anchor block is uplift, UPL. For this, EC7 provides two factors for permanent actions, abbreviated

here as $\gamma_{G;dst}$ (generally > 1) for the destabilising force and $\gamma_{G;stb}$ (generally < 1) for the stabilising force; the factor for the variable destabilising force is $\gamma_{Q;dst}$ (> 1).

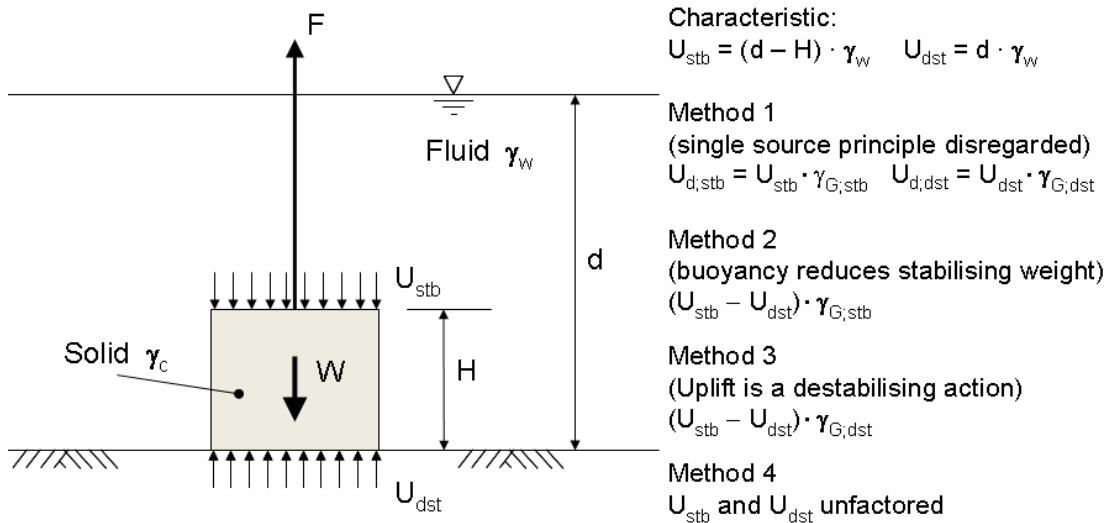

Figure 4. Submerged anchor block

It is clear that the characteristic weight of the block, W_k , will be multiplied by $\gamma_{G;stb}$ to derive the design value for UPL, and the characteristic anchor force, F_k , will be multiplied by $\gamma_{Q;dst}$. Four possible methods of applying partial factors to the water pressures could be considered.

In Method 1, the destabilising water pressure beneath the block is multiplied by $\gamma_{G;dst}$, and the stabilising water force above the block by $\gamma_{G;stb}$. Thus the limit state requirement is:

$$W_k \cdot \gamma_{G;stb} + U_{stb} \cdot \gamma_{G;stb} \geq U_{dst} \cdot \gamma_{G;dst} + F_k \cdot \gamma_{Q;dst} \quad (1)$$

In Method 2, the buoyant weight of the block is taken to be the stabilising force. The limit state requirement is:

$$(W_k - \Delta U) \cdot \gamma_{G;stb} = W_k \cdot \gamma_{G;stb} + (U_{stb} - U_{dst}) \cdot \gamma_{G;stb} \geq F_k \cdot \gamma_{Q;dst} \quad (2)$$

$$\text{where } \Delta U = U_{dst} - U_{stb}$$

In Method 3, the two water forces are recognised as coming from a “single source” which is considered to be destabilising. The limit state requirement is:

$$W \cdot \gamma_{G;stb} - \Delta U \cdot \gamma_{G;dst} = W_k \cdot \gamma_{G;stb} + (U_{stb} - U_{dst}) \cdot \gamma_{G;dst} \geq F_k \cdot \gamma_{Q;dst} \quad (3)$$

In Method 4, water pressures are not factored. The limit state requirement is:

$$W \cdot \gamma_{G;stb} - \Delta U = W_k \cdot \gamma_{G;stb} + (U_{stb} - U_{dst}) \geq F_k \cdot \gamma_{Q;dst} \quad (4)$$

Thus the factors applied to the water forces may be summarised as shown in Table 2, with the resulting equations. The design water pressures are shown in Figure 4b; the pressures for Method 1 coincide with those of Method 2 above the block and with those of Method 3 below the block. In Figure 5, the allowable characteristic anchor force, F_k , is plotted against the “Density ratio” γ_c/γ_w ; F_k is normalised by dividing by W_k . For the purpose of this figure, the values of partial factors have been taken from the UK National Annex: $\gamma_{G;dst} = 1.1$, $\gamma_{G;stb} = 0.9$, $\gamma_{Q;dst} = 1.5$.

Table 2 Summary of factors applied to water forces in Example 1.

Method	Description	Factor applied to water forces		Maximum allowable value for F_k/W_k
		U_{dst}	U_{stb}	
1	Treat destabilising and stabilising water forces separately	dst	stb	$(W_k \cdot \gamma_{G;stb} + U_{stb} \cdot \gamma_{G;stb} - U_{dst} \cdot \gamma_{G;dst}) / W_k \cdot \gamma_{Q;dst}$ $= \gamma_{G;stb}/\gamma_{Q;dst} + (\gamma_w/\gamma_c)(d/H-1) \cdot \gamma_{G;stb}/\gamma_{Q;dst} -$ $(\gamma_w/\gamma_c)(d/H) \cdot \gamma_{G;dst}/\gamma_{Q;dst}$
2	Consider buoyant weight of block as the stabilising force	stb	stb	$(W_k \cdot \gamma_{G;stb} + (U_{stb} - U_{dst}) \cdot \gamma_{G;stb}) / W_k \cdot \gamma_{Q;dst}$ $= \gamma_{G;stb}/\gamma_{Q;dst} - (\gamma_w/\gamma_c) (\gamma_{G;stb}/\gamma_{Q;dst})$
3	Consider both water forces as coming from a single source, which is destabilising	dst	dst	$(W_k \cdot \gamma_{G;stb} + (U_{stb} - U_{dst}) \cdot \gamma_{G;dst}) / W_k \cdot \gamma_{Q;dst}$ $= \gamma_{G;stb}/\gamma_{Q;dst} - (\gamma_w/\gamma_c) \cdot (\gamma_{G;dst}/\gamma_{Q;dst})$
4	Unit factors on water	1	1	$(W_k \cdot \gamma_{G;stb} + (U_{stb} - U_{dst})) / W_k \cdot \gamma_{Q;dst}$ $= \gamma_{G;stb}/\gamma_{Q;dst} - (\gamma_w/\gamma_c) \cdot (1/\gamma_{Q;dst})$

Figure 5a shows that for Method 1 the allowable anchor force depends on the water depth (normalised by dividing by the height of the block). This occurs because different factors are applied to the destabilising and stabilising water forces. This is considered to be physically unreasonable, except, perhaps, in very rare circumstances for which the pressures above and below the block are independent because they are not from a “single source”. As the water becomes deeper, the allowable anchor force reduces for the same block, and for $d/H=5$ no force can be taken unless the density of the block is more than twice that of water.

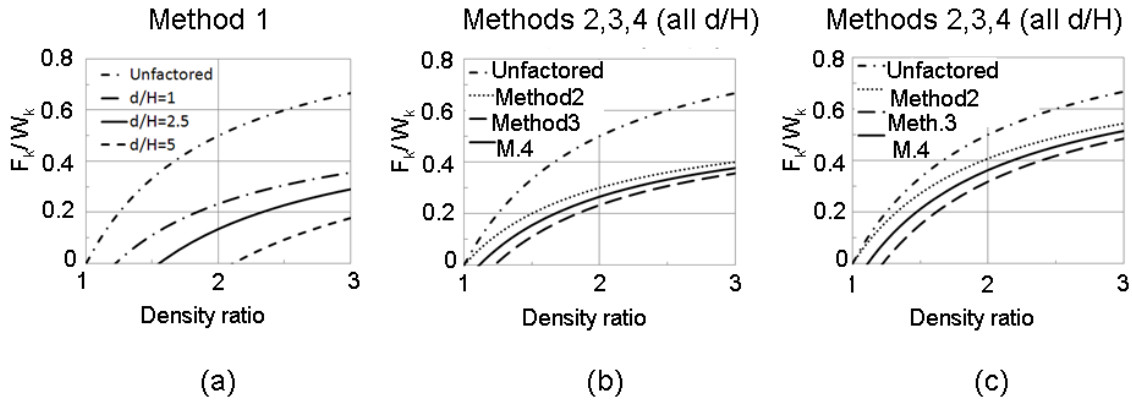

Figure 5. Submerged anchor block – allowable anchor force in relation to density of block. (a) Method 1, (b) Methods 2 to 4, (c) Methods 2 to 4 assuming the anchor force is permanent.

The results for Methods 2 to 4, shown in Figure 5b, are independent of the water depth. For Method 2, the allowable F_k tends towards the unfactored value for low density ratios. Figure 5c is similar, except that it is assumed that the anchor force is permanent, rather than variable (ie $\gamma_{G,dst}$ has been applied to F in place of $\gamma_{Q,dst}$). In this case, Method 2 provides very little safety for low density ratios. A further important objection to Method 2 is that it applies a reduction factor ($\gamma_{G,stb} < 1$) to the buoyancy effect of the water, which is clearly a destabilising effect.

Methods 3 and 4 both follow the single source principle, and so avoid the need to distinguish between stabilising and destabilising actions of water pressures. Method 3 provides apparently reasonable results, though in effect the density of water is factored, which could lead to difficulties in more complex situations where the strength of soil is affected by water pressures. This difficulty might be avoided if all actions of connected water are combined to find a resultant destabilizing uplift force, which is then factored by $\gamma_{G,dst}$. This method clearly shows where safety on water pressures is applied, by considering the block weight and water uplift separately.

Method 4, with no factors on the water forces, also provides reasonable results, indicating that for this problem it may not be necessary to apply factors to water pressure, either directly or indirectly. The resultant of water actions, which is destabilising, is not increased, so the overall factor of safety is lower than obtained with Method 3.

If the factors on water pressure are set to 1.0, all four methods become the same, in regards to their treatment of water.

6.3 Example 2 – group of submerged tanks

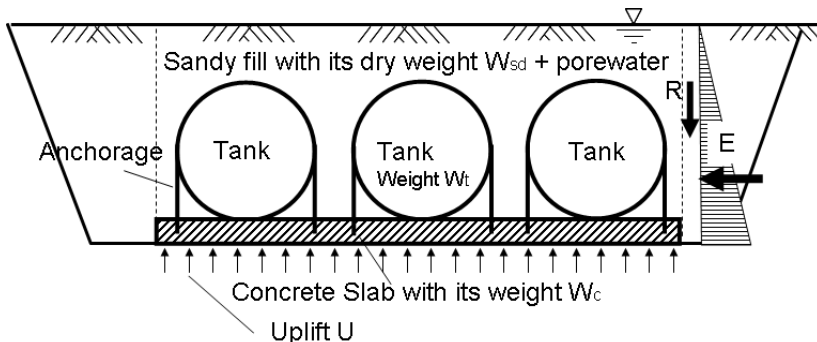

Figure 6. Group of submerged tanks on a concrete slab

The example in Figure 6 includes a sand fill with its pore volume filled with water. Again there are different methods to fulfil the ultimate limit state requirement. In the following considerations the influence of friction forces at the sides of the fill is omitted.

Prioritizing the single source principle, a resultant uplifting force, which is the difference between all water pressures acting upwards and downwards, has to be used as destabilizing force. This is mathematically the same as using the unit weight of water multiplied with the volume of the slab and of the tanks and of the grains of the soil as the destabilizing force. Physically and philosophically there might be a difference as the second way uses the weight of water that is absent, because of the presence of other solids, as a destabilizing force. The second way addresses the Archimedean effect of water rather than its direct actions, but it will be used in the following to work out the difference to the other applied methods. EC 7 allows for looking at the effects as well as for looking at the actions themselves.

Stabilizing forces are the weight of the concrete slab W_c + the weight of the tanks W_t + the weight of the dry sand W_{sd} . There is a danger of mistake with the effects of the sand fill: the volume of the fill must be multiplied with γ_d (dry density) to find the stabilizing weight and with $(1 - n) \cdot \gamma_w$ (n = porosity, γ_w = unit weight of water) to find the-uplift acting on the grains. The limit state requirement is:

$$\gamma_w \cdot \text{Volume}(\text{slab} + \text{tanks} + \text{soilgrains}) \cdot \gamma_{dst} \leq \text{Weight}(\text{slab} + \text{tanks} + \text{soilgrains}) \cdot \gamma_{stb} \quad (5)$$

The formulation shows that an increase of the density of the soil which increases the number of grains in the volume leads to increasing both destabilizing and stabilising forces and effects. The necessary weight of the slab may be expressed as

$$\text{Weight}(\text{slab}) \geq \gamma_w \cdot \text{Volume}(\text{slab} + \text{tanks} + \text{soilgrains}) \cdot \gamma_{dst}/\gamma_{stb} - \text{Weight}(\text{tanks}) - \text{Weight}(\text{soilgrains})$$

With a second method it can also be looked at a horizontal cross section at the base of the concrete slab. Destabilising is the integral of uplifting water pressure U at this depth, stabilising are W_c , W_t , W_{sd} and the weight of the water in the pore-spaces of the sand W_w :

$$U \cdot \gamma_{dst} \leq (W_c + W_t + W_{sd} + W_w) \cdot \gamma_{stb} \quad \text{this is identical to}$$

$$\gamma_w \cdot \text{Total Volume} \cdot \gamma_{dst} \leq \text{Weight}(\text{slab} + \text{tanks} + \text{soilgrains} + \text{Water in pore-space}) \cdot \gamma_{stb} \quad (6)$$

The necessary weight of the slab comes from the requirement

$$\text{Weight}(\text{slab}) \geq \gamma_w \cdot \text{Volume}(\text{slab} + \text{tanks} + \text{soilgrains} + \text{pore-space}) \cdot \gamma_{dst}/\gamma_{stb} - \text{Weight}(\text{tanks}) - \text{weight}(\text{soilgrains}) - \text{Weight}(\text{Water in pore-space})$$

With this consideration the action of the water beneath and above the slab is factored with different partial factors, thus the single source principle is violated. This could be hidden by using the saturated unit weight of the sand instead of $W_{sd} + W_w$ which mathematically would be the same. However there might be good reasons to apply a partial factor to the saturated weight including the weight of water in order to account for other secondary effects and to be very cautious about the stabilizing weight.

The difference between both requirements is to be found in the handling of the water in the pore-spaces of the sand. In (5) it is omitted on both sides of the requirement. In (6) its weight $\cdot \gamma_{dst}$ enlarges the left side and its weight $\cdot \gamma_{stb}$ enlarges the right side. Applying (6) leads to a concrete slab with higher weight than by applying (5). The difference in the weight of the slab is $\text{Volume}(\text{pore-spaces}) \cdot \gamma_w \cdot (\gamma_{dst}/\gamma_{stb} - 1)$.

In a 3rd method the actions of water can be taken as design actions without applying partial factors:

$$\gamma_w \cdot \text{Volume}(\text{slab} + \text{tanks} + \text{soilgrains}) \leq \text{Weight}(\text{slab} + \text{tanks} + \text{soilgrains}) \cdot \gamma_{stb} \quad (7)$$

or identically

$$U \leq W_w + (W_c + W_t + W_{sd}) \cdot \gamma_{stb}. \text{ This leads to a necessary weight of the slab of}$$

$$\text{Weight}(\text{slab}) \geq$$

$$(U_{\text{at the bottom of the slab}} - \text{Weight}(\text{Water in pore-space}))/\gamma_{stb} - \text{Weight}(\text{tanks}) - \text{weight}(\text{soilgrains})$$

which leads to the most economical design and to the lowest total safety. By choosing this method and maintaining former total safety it is necessary to decrease the partial factor for stabilizing forces.

6.4 Example 3 – Gravity construction on clay retaining free water

The construction in Figure 7 has to be checked for its bearing capacity on the subsoil and not to fail by sliding or toppling. It is doubtful whether it could, in reality, topple without first having a bearing failure either in the ground or in the structure, which ever failed first.

A further requirement often imposed is that the resultant force through the base should not approach too close to the edge. For example, a “middle third” rule might be imposed. Eurocode 7 has a “middle two-thirds” rule, but allows the resultant force to approach even closer to the edge of the base if the design has been reviewed with exceptional care. In practice, it might be unwise to allow the resultant force to lie outside the middle two-thirds. For this type of problem, the relevant resultant force will generally be the design effective force (i.e. excluding water pressure) between the structure and the ground. A further practical consideration is that it might be necessary to maintain total pressure greater than water pressure u_2 at the rear of the block, in order to stop separation that could allow water to penetrating, changing the pressures beneath the base. However, for simplicity, this is not considered here. Physically the water pressure u_1 cannot exceed $\gamma_w \cdot H$, as the water would flow over the construction. Nevertheless safety elements have to be introduced for the above mentioned checks. The water pressures u_1 and u_2 are from the same source, thus partial factors on the actions u_1 and u_2 should ideally be the same.

The effect of u_1 is a horizontal force $F_H = u_1 \cdot H/2$ at the base of the gravity construction. The resistance against sliding is $R_H = (W - B \cdot u_2/2) \cdot \tan\phi$. Three possible approaches can be considered for this problem: (a) factoring water pressures; (b) factoring the effects of water pressures; (c) relying on use of “worst” water pressures or levels, without application of factors. The partial factor to be applied on the actions (γ_f) and effects (γ_e) of water pressure which are clearly defined and not subjected to large stochastic variations has a wide scatter in the different European countries.

As an example of approach (a), the Dutch National Annex to EC7 applies $\gamma_U = 1.2$ to the water pressures. The water pressure in the resistance term is also factored with the same partial factor γ_U of 1.2 (one source principle) in combination with a favourable partial load factor $\gamma_G = 0.9$ for the weight of the block and a partial material factor of 1.15 on $\tan \phi$.

One way to deal with the above mentioned constraints is to apply partial factors on the effects of actions (approach (b)) rather than on the actions themselves and to apply safety checks in which the increase of destabilizing effects accounts for any uncertainty – not only for uncertain unit weight or water table. This is done as an example for the check against sliding. Applying a partial factor γ_e on the effect F_H and a partial factor γ_R on the resistance R_H leads to the formal check: $F_H \cdot \gamma_e \leq R_H/\gamma_R$. The German NA requires $\gamma_e = \gamma_G = 1,35$ in geotechnical design and for groundwater influence.

Approach (c) using $\gamma_f = 1$ is preferred by the UK NA to EC7, though some discretion is left with the designer and use of approach (a) is allowed. The design will usually be governed by the analyses of sliding or bearing, for which the safety margin is given by the factors on soil strength. In some cases, the “middle two-thirds” rule will govern.

In connection with water tables within concrete structures such as locks (Figure 8) effects due to variable water tables as the bending moment in cross section a - a may also be factored by $\gamma_e = \gamma_Q = 0$ (favourable) or $\gamma_e = \gamma_Q = 1,5$ (unfavourable).

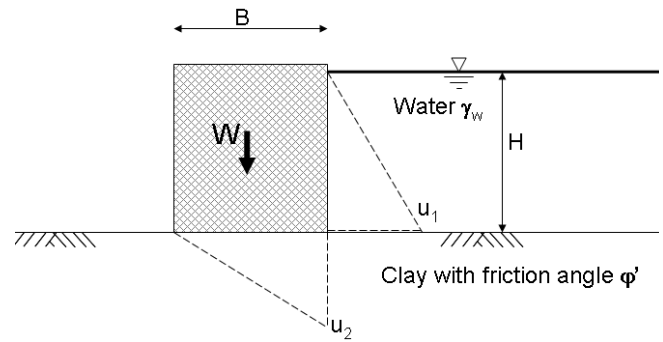

Figure 7. Gravity construction retaining free water

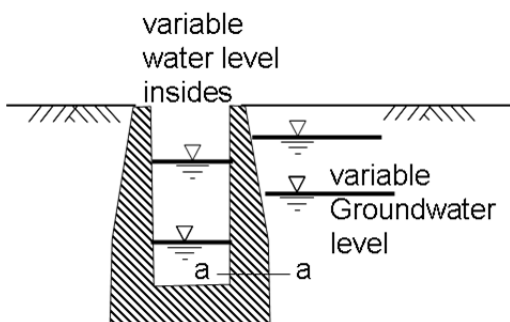

Figure 8. Lock with its water actions

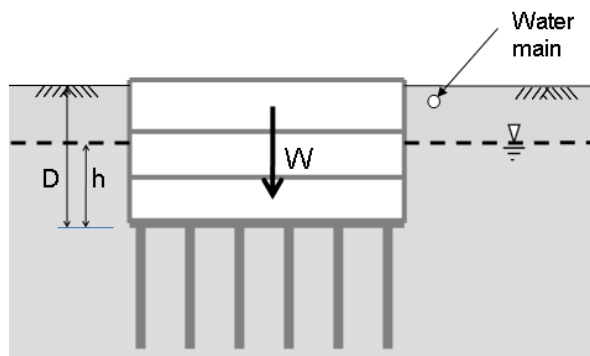

Figure 9. Deep basement subject to uplift

6.5 Example 4 – Basement with tension piles

Figure 9 shows a deep basement extending below the water table. No drainage is provided beneath the base slab, so hydrostatic water pressures are expected. Some unplanned variation in the water level is possible, for example due to leakage from a water main. The total weight of the structure, which could include superstructure built on the basement, is W and its area in plan is A . If needed, tension piles are to be provided to prevent uplift.

The uplift force beneath the basement is given by $U = \gamma_w Ah$.

If the characteristic uplift force U approaches or exceeds the characteristic weight W , the tension force T in the piles has to be derived. For ULS UPL we find

$$U_k \cdot \gamma_{G,dst} \leq W_k \cdot \gamma_{G,stb} + T_d \quad \text{which means } T_d = U_k \cdot \gamma_{G,dst} - W_k \cdot \gamma_{G,stb} \quad (8)$$

It is also possible to look at the problem as ULS STR/GEO. Then we get

$$U_k \cdot \gamma_G - W_k \cdot \gamma_{G,inf} = T_d \quad \text{and} \quad T_d \leq R_d = R_k / \gamma_{P,t} \quad (9)$$

As in most countries the partial factors $\gamma_{G,dst}$ and γ_G are different as well as $\gamma_{G,stb}$ and $\gamma_{G,inf}$ are different there is a need for guidance and clarity. The German NA to DIN EN 1990 gives a special set of partial factors $\gamma_{G,dst}^*$ and $\gamma_{G,stb}^*$ for cases where the resistance of building elements is necessary to fulfil ULS EQU and UPL requirements. Their values are $\gamma_{G,dst}^* = 1,35$ and $\gamma_{G,stb}^* = 1,15$ instead of $\gamma_{G,dst} = 1,05$ and $\gamma_{G,stb} = 0,95$ or $\gamma_G = 1,35$ and $\gamma_{G,inf} = 1,0$ leading to intermediate results. But this again means factoring of water pressure which is physically connected with the already discussed problems.

In situations where U greatly exceeds W , the precise sequence of calculation in which the factors are applied and the value of the partial factors may vary according to national practice, but the outcome is much the same. The case of W greatly exceeding U , which would require compression piles if the slab is suspended, is not considered here.

The problem is more debatable when the characteristic (unfactored) values of W and U are close, especially in formats that use $\gamma_{G,inf} = 1.0$, which is common. If $W_k = U_k$ and $\gamma_G > 1$ is applied to water pressure, tension piles are needed, but if water pressure is not factored or adjusted in some other way no piles are needed, even if a factor is applied to the resultant ($U_k - W_k$), which in this case equals zero.

To illustrate this problem, suppose n piles are to be provided each with a characteristic resistance in tension R_k . For the purpose of plotting results of calculations, it is convenient to define $W_w = \gamma_w AD$; this is not the buoyancy force, which is $U_k = \gamma_w Ah$. When $U_k = W_k$, $h/D = W_k/W_w$. In Figure 10 the number of piles required, n , represented by nR_k/W_w , is plotted against h/D for a typical case in which $W_k/W_w = 0.25$. The values of partial factors used here are adopted for illustration only, and may not represent any particular national practice. Some countries prefer to view tension piles as providing a favourable action, which would also lead to adoption of different factors. In Figure 10, the critical area of the graph is shown as an enlarged detail.

In the unfactored case, piles only become necessary when $h/D > W_k/W_w = 0.25$ in this example. If factors are applied to the unfactored resultant force in the piles, together with pile resistance factors, a line such as line (b) is obtained, for which $\gamma_R = 1.7$ was used for the piles. The gradient of this line depends on the values of the factors, but when $h/D = W_k/W_w = 0.25$ no tension piles will be provided and there is no reserve of safety for deviation from the characteristic values of water pressure and weight. This is considered to represent an unacceptable situation.

If the water pressure beneath the base is multiplied by a partial factor $\gamma_G = 1.35$, a line such as line (c) in Figure 10 is obtained; in plotting this line a lower value of pile resistance factor $\gamma_R = 1.3$ has been adopted, in acknowledgement of the increased value of γ_G . In this case, a reserve of safety is provided when $h/D = W_k/W_w$, requiring some tension piles. However, the number of piles might be regarded as excessive for the case of a high water table, h/D approaching 1, where the water pressure beneath the base becomes physically unreasonable.

An alternative approach could be to avoid factoring water pressure but to require an increase in the water head h . For example, line (d) in Figure 10 shows the results when the free height above the water table ($D-h$) is reduced by 10%. This has an advantage in the case where h is large (eg $h/D = 1$) that it does not enhance the water pressures unreasonably, requiring too many piles. The amount by which the water head should be raised is difficult to specify for general application in a code of practice, however. If this approach is preferred, it may be necessary to rely more heavily on the expertise of the designer to decide what margin is appropriate. This is consistent with the approach of EC7 {2.4.6.1(6)P} using direct assessment of design values: “When dealing with ground-water pressures for limit states with severe consequences (generally ultimate limit states), design values shall represent the most unfavourable values that could occur during the design lifetime of the structure.”

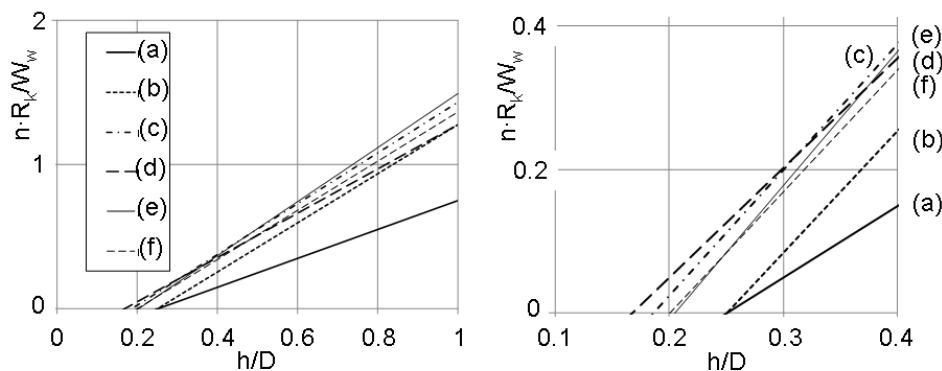

Figure 10. Number of piles required (normalised). (a) unfactored, (b) pile resistance factored, (c) $g_G = 1.35$ on water pressure, (d) water table adjusted, (e) UPL, (f) $g_{G,fav} = 0.8$ on weight.

In relation to EC7, the discussion above relates to the “STR/GEO” requirements normally used for finding the number and required resistances of piles. EC7 has another requirement for uplift cases, UPL, which is normally understood to require a factor $\gamma_{G,dst} > 1$ applied to uplifting water pressure and a factor $\gamma_{G,stb} < 1$ applied to stabilising total weight. Line (e) in Figure 10 is plotted for typical values $\gamma_{G,dst} = 1.1$, $\gamma_{G,stb} = 0.9$, with the resistance factor for the piles $\gamma_R = 1.7$. This requirement can produce sensible results provided that (a) it is agreed that piles are to be designed using loading derived from UPL and (b) an appropriate system and values of factors is adopted in applying these loads to pile design. As with other schemes involving factors on water pressure, it becomes unreasonable when the water table approaches ground level ($h/D=1$) and may demand more piles than are really needed.

In this problem, it is necessary to change the water pressure or the building weight from their characteristic values in order to increase safety when U_k is close to W_k . A possible alternative, not considered by Eurocode 7 but recommended for further consideration, would be to apply a reduction factor to the weight of the building, say 0.8, while leaving the water pressure unfactored. This is shown as line (f) in Figure 10, plotted with $\gamma_R = 1.7$. This provides safety when $h/D = W_k/W_w$, but it avoids factoring water pressure and has a smaller effect than some of the alternatives, such as UPL, when $h/D=1$. The results of the approach using $\gamma_{G,dst}^* = 1,35$ and $\gamma_{G,stb}^* = 1,15$, in which water pressure is factored, are almost identical with this.

6.6 Example 5 – Anchored quay wall

In Figure 11 an anchored sheetpile quay wall is shown. Water levels in the retained ground and in the excavation vary. The sheet pile is driven into the clay layer, therefore the water pressures inside and outside the building pit are different and do not represent a single source.

It has to be clarified if the water levels are already considered “the most unfavourable values that could occur during the design lifetime of the structure” (EN1997-1, 2.4.6.1 (6)) or “the most unfavourable occurring in normal circumstances”. In the first case the corresponding water pressures could directly be considered as design values. On the other hand German and Dutch requirements even look at water pressures due to water tables belonging to a flood occurring statistically only once in 50 to 100 years as characteristic values and their effects are factored with γ_G . In the second case (“the most unfavourable occurring in normal circumstances”) it is doubtless that safety elements such as additional water heads or application of partial factors have to be applied. The water pressures in case 2 are considered as characteristic values.

In the UK two separate calculations are required for the two combinations of Design Approach 1. The way in which design water pressures are derived is not fully prescribed, leaving the designer to judge what is appropriate in particular circumstances, as described above in 4.2.2. One approach compatible with DA1 is to use (a) “the most unfavourable occurring in normal circumstances” in Combination 1, applying a partial factor of 1.35 to action effects, such as the resulting bending moment of the sheet pile, and (b) “the most unfavourable values that could occur during the design lifetime of the structure” in

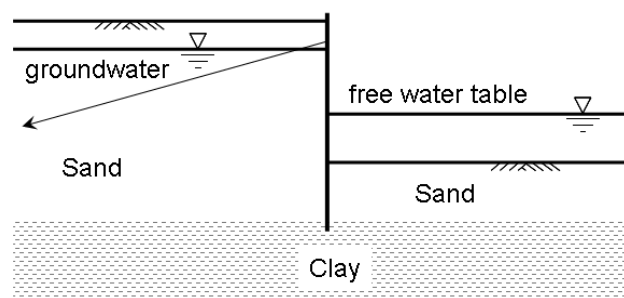

Figure 11. Anchored quay wall

Combination 2, with unit factors on all permanent actions and their effects. The application of the factors in (a) indicates that the approach used for water pressures is DA1*.

In Germany (DA2*) only the characteristic water pressures are used in the calculations and a partial load factor is applied at the end of the calculation to the loading effects for every critical part (anchor, sheet pile wall, reactive force to be held by passive earth pressure).

In the Netherlands (DA3), the design value of the water pressure is derived by application of an offset to the water levels, i.e. lowering water level by 0.20 m at the low side and increasing the water level by 0.05 m at the high side. The ULS-check to determine the sheet pile dimensions and anchor capacity, is then performed in combination with material factors on the soil friction properties.

All three approaches are probably adequate in most circumstances, and all three have advantages and disadvantages. The UK approach is the least prescribed, relying more heavily on engineering expertise, and so might be thought to have a greater risk of misjudgements and arguments between parties involved in the design. It has the potential, however, to cover a very wide range of circumstances and aims to avoid a need for designers to violate physical principles. The German approach could provide insufficient resistance if a small change in water pressures could lead to a change of more than 35% in action effects; similarly, if very little change of action effects is possible it could be unnecessarily conservative. It has the advantage, however, of relatively complete prescription leaving less room for argument or mistakes by designers. The Dutch approach using DA3 is similar in principle to DA1 Combination 2, but the water levels to be used are more strictly prescribed. This leaves less room for debate, but the values prescribed might not be suitable in all circumstances, or for a wider range of problem types.

6.7 Example 6 – Gravity wall retaining free water – level slightly uncertain

An L-shaped wall is retaining 3 m depth of water (Figure 12). In a very unlikely event of a blocked drain pipe at 3 m height, however, the water level may increase up to 4 m before the water flows over the wall. The soil below the wall consists of clay, with the concrete cast directly upon it. The downstream groundwater level is at ground level.

The water level increase up to 4 m height can be considered as an accidental situation, for which most codes and countries apply a partial factor of 1.0 to the actions. Therefore two load cases are considered with 4 m water height with a partial factor of 1.0 and 3 m water height with partial factors as discussed in 6.4 above. Discussions about the water pressure beneath the base, u_3 in Figure 12, are also similar to those in section 6.4.

For EQU, the accidental case is always governing, as the ULS-state for the accidental water level results in a u_2 -value of 40 kPa compared to a design water pressure u_2 of 33 kPa for the 3 m water level with a partial factor of 1.1. For sliding and bearing, both the 3 m and 4 m water levels should be considered, with the appropriate factors for normal and accidental conditions; which case is more critical depends on the factors used. For illustration purposes, a partial factor of 1.35 is used in this example. For structural design, the bending moment in the wall for 4 m depth is $\gamma_w 4^3/6 = 107$ kNm/m and for 3 m with a 1.35 partial factor it is $1.35\gamma_w 3^3/6 = 61$ kNm/m. So if the 4 m level has to be considered, a 1.35 factor on 3 m is not adequate.

In water constructions in Germany the effects of extreme water tables or of a damage or failure of sealing systems is regularly handled as an accidental design situation by using special partial factors equal or near to 1. There even exists a separate set of partial factors (factors on effect of actions as well as on resistance) assigned to transient design situations which is applied in connection of the occurrence of an exceptional large action or for an action that is planned to happen only once.

6.8 Example 7 – Groundwater pressures below a basement

In Figure 13 a basement is shown with floor levels at -2.8 m and -8.2 m. The floors are supported by tension piles to overcome uplift. The characteristic water level is at -1.0 m. For the evaluation of the tension capacity of the piles for STR/GEO, the water load must be multiplied by a load factor of 1.35 (or 1.2 in the Netherlands) or a partial factor γ_E should be applied to the load effects.

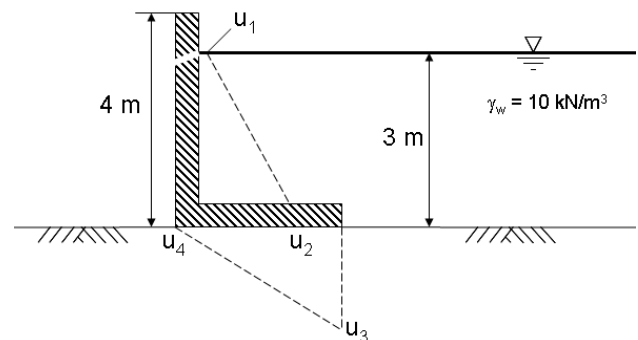

Figure 12. Gravity wall retaining free water

This would lead to a design water pressure of $1.35 \cdot 18 = 24 \text{ kPa}$ against the upper floor and $1.35 \cdot 72 = 97 \text{ kPa}$ at the lower floor. These pressures correspond with water levels of -0.4 m and $+1.5 \text{ m}$ for the upper and the lower floor respectively. These design levels are not equal for the same structure and the water level of $+1.5 \text{ m}$ may be physically impossible!

Possibilities to deal with these apparent inconsistencies are:

1. Consider the water pressures as a load and apply a partial safety factor to the load. This safety factor is then considered part of the overall safety concept and does not reflect solely the uncertainty of the load.
2. Use a constant offset in the water level to incorporate the uncertainty in water level. However, an offset would result in a lower safety for the lower floor and a higher safety factor for the upper floor.
3. Apply a partial safety factor on the water pressures, but consider a maximum level for the water table, equal to ground level (as suggested in EC7 clause 2.4.6.1). The water pressures cannot exceed this limit value. Again, for the lower floor the factor of safety is below 1.35!

The Eurocode does not give a clear solution in these cases. When the water level at ground level can be considered as an absolute limit (like example 6), the corresponding water pressures can be considered as an accidental load and Option 3 would be applicable.

However, when the water pressures are caused by water in a confined deep aquifer, groundwater head above ground level is well possible. In this case Options 1 or 2 apply.

Both options 1 or 2 are possible. As described above, Option 1 would lead to maintaining the overall safety concept for the structure, but ignores the magnitude of variation in water table. Option 2 would consider the limited water table variation, but does not incorporate other uncertainties in the overall safety of the structure.

When adopting a partial factor γ_E to the load effects, the calculation is performed using characteristic values for the water pressures. This case agrees with Option 1.

7 RECOMMENDATIONS

Through intensive discussions, the authors have been able to reach agreement on the following points:

1. The effects of water pressures are very important in geotechnical design. Their actual values can have significant uncertainties, and values outside the range anticipated in design can cause major failures.
2. Partial factor design applies factors to a small number of leading, or “primary” actions. In real design situations, secondary actions of relatively small but unpredictable nature and magnitude should also be accommodated; that is, a degree of robustness it required. Often, these are accommodated by increasing the partial factors applied to primary actions or action effects.
3. Designers must explicitly accommodate the worst water pressures that could reasonably occur. Reliance on factors of safety together with less extreme water pressures or water levels may give a false sense of security.
4. Application of partial factors to the density of water should generally be avoided.
5. One useful way to maintain a prescribed degree of safety is to require an offset in water pressure, raising or lowering the water surface or piezometric level.
6. The single source concept should be applied whenever possible.
7. The “star” approach (DA2* or DA1*, introduced here) has advantages when dealing with problems dominated by water pressures because it avoids the application of partial factors to the density of water or to water pressures. This means that partial factors are applied to action effects rather than to actions themselves. The details of its use depends on the way other partial factors are applied, to resistances or to material strengths, and on their values. In situations where material strength is important (STR/GEO), if fairly low factors are applied to resistance (1.1) it might be necessary to enhance the

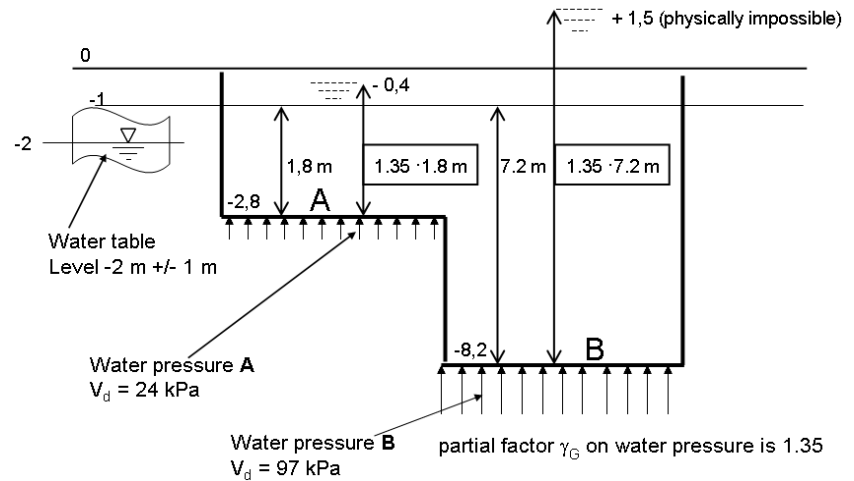

Figure 13. Groundwater pressures below a basement

loads (or load effects such as an uplifting force), even when they are very certain. But if larger factors are applied to resistance (1.25 or 1.4), then it may not be necessary to enhance loads where they are well defined.

8. In uplift problems, it is necessary to vary either water pressures or the magnitudes of favourable, stabilising weight, in order to ensure safety in view of possible secondary actions. In order to avoid factoring water pressures, the possibility of a reduced factor on favourable weight, perhaps between 0.8 and 0.9 should be considered.
9. To prevent toppling failure of structures loaded laterally by water pressure, a “middle 2/3rds” rule could be considered, applied to unfactored actions, or to actions with unit factors.
10. Although there are obvious advantages in making codes of practice as precise and prescriptive as possible, the need for engineering expertise and careful evaluation of the full range of credible scenarios cannot be replaced. This is particularly true of situations in which water pressure has a dominating role.

The following points are not agreed among the authors and remain to be debated and researched further. In some cases, appropriate conclusions may depend on other features of the safety formats adopted, for example the differing Design Approaches of Eurocode 7.

11. Whether it is desirable to apply factors to water pressures. Several approaches that avoid this have been discussed, but in some approaches factors are applied to water pressures in some circumstances.
12. Whether it is reasonable to apply partial factors to forces (action effects) directly derived from water pressures. It is agreed that this may raise problems, which have been discussed, but the authors could not agree that it can always be avoided.
13. The use of the “star” approach, factoring action effects, in cases where it is directly equivalent to factoring water pressures, either complying with the “single source” principle or not compliant. The problem particularly relates to situations in which equilibrium is not maintained throughout the geotechnical calculations of stability, including sliding, bearing, toppling and uplift. An example is given by approach (b) in Example 3 above, where the design horizontal force transmitted to the ground is not in equilibrium with the water pressures. Less concern is felt about application of factors to action effects internal to structures, such as bending moments in walls and slabs or forces in piles.

REFERENCES

- AASHTO (2008) LRFD Bridge Design Specifications, 4th edition, 2007 with 2008 Interim Revisions. American Association of State Highway and Transportation Officials.
- Beeby, AW & Simpson, B (2001) A proposal for partial safety factors for soil pressures in BS8110. *The Structural Engineer*.
- BS8002 (1994) Code of Practice for Earth Retaining Structures. BSI.
- BS 6349-1 (2000) Maritime structures - Part 1: Code of practice for general criteria. BSI.
- CUR 166 (2008), Damwandconstructies (Earth retaining structures), CUR Bouw&Infra, The Netherlands
- Davies, RV (1984) Some geotechnical problems with foundations and basements in Singapore. *Proc Int Conf on Tall Buildings, Singapore*, pp643-650.
- DIN 1054 (2005) – Subsoil – Verification of the safety of earthworks and foundations.
- DIN 4084 (draft 2002) – Subsoil – Calculation of embankment failure and overall stability of retaining structures.
- DIN 19700-10 (2004) – Dam Plants – General specifications.
- DIN 19702 (1992) – Stability of Solid Structures in Water Engineering.
- DIN 19712 (2007) – River Dikes.
- Gaba, A.R, Simpson, B. Powrie, W. & Beadman, D.R. 2003. Embedded retaining walls: guidance for economic design. CIRIA Report C580.
- Orr, T.L.L. (2005). Model Solutions for Eurocode 7 Workshop Examples. Trinity College, Dublin.
- PD6694-1(2011) Recommendations for the design of structures subject to traffic loading to BS EN 1997-1:2004. BSI.
- Ramaswamy, S.D. (1979) "Some Aspects of Practice and Problems of Foundations in Singapore" *Proc. 6th Asian Regional Conf. on Soil Mech. and Found. Eng.*, Singapore, 1979.
- Simpson, B. (2011) Water pressures. *Proc. 2nd International Workshop on Evaluation of Eurocode7*, Pavia, 12-14 April 2010.
- Simpson, B and Hocombe, T (2010) Implications of modern design codes for earth retaining structures. *Proc ER2010, ASCE Earth Retention Conference 3*, Seattle, Aug 2010.
- Simpson, B., Blower, T., Craig, R.N. and Wilkinson, W. B. (1989) The engineering implications of rising groundwater levels in the deep aquifer beneath London. CIRIA Special Publication 89, 1989.
- Simpson, B, Morrison, P, Yasuda, S, Townsend, B, and Gazetas, G (2009) State of the art report: Analysis and design. *Proc 17th Int Conf SMGE, Alexandria, Vol 4*, pp. 2873-2929.
- Stroud, M.A. (1987) The Control of Groundwater. General Report and State of the Art Review to Session 2 of IX ECSMFE Dublin