

# COMPARISON OF LABORATORY AND FIELD MEASUREMENTS OF BRIDGE PIER SCOUR

LEE, SEUNGOH, STURM, T. W.,

*School of Civil and Environ. Engrg., Georgia Institute of Technology  
Atlanta, GA 30332-0512 USA*

GOTVALD, A., LANDERS, M.

*U. S. Geological Survey, 3039 Amwiler Road  
Atlanta, GA 30360-2824 USA*

While the importance of accurate predictions of prototype scour depths around bridge foundations cannot be overstated, the basis for scaling laboratory measurements up to the field remains a serious and complex problem. In this study, a full three-dimensional laboratory scale model of a prototype bridge on the Chattahoochee River near Cornelia, Georgia was constructed for comparison with continuous scour and velocity measurements made in the field. The laboratory model was constructed at an undistorted scale of 1:40 including the complete river bathymetry as well as the bridge pier bents and abutments. The velocity field and the scour contours were measured with an acoustic Doppler velocity meter. In the field portion of the study, the bridge piers were instrumented with 4 fathometers that provided continuous measurements of the channel bottom elevation near the central pier bent. In addition, a side-looking acoustic Doppler velocity meter was attached to the upstream pier of the pier bent for measurements of velocity components across the cross section. A bank-full flow event occurred in July 2003 which was reproduced in the laboratory model. Results are presented that compare measurements of the scour hole depth and velocities in the field with the laboratory model measurements. The implications for laboratory modeling of bridge scour are discussed.

## **1 Introduction**

Although numerous formulas for the prediction of bridge pier scour depths have been developed based on laboratory experiments as summarized by Melville and Coleman (2000) or Sturm (2001), for example, considerable doubt remains concerning their applicability to large-scale prototypes. Scour-depth estimates based on laboratory data tend to overestimate actual pier scour depths measured in the field (Landers and Mueller 1996). This situation is partly due to the sediment scale effect that limits the size of the sediment that can be used in the laboratory without it becoming so fine-grained that interparticle forces that may not exist in the field become dominant in the laboratory (Ettema et al. 1998). Furthermore, field measurements of bridge pier scour that have been obtained in the past with mobile instrumentation during floods show considerable scatter

when analyzed because of several interdependent variables acting together in an uncontrolled fashion to determine the final scour depth. Issues of unsteadiness and nonuniformity of the flow as well as sediment bedforms further complicate the problem of field measurement of scour. In this context, a combined laboratory, numerical, and field study has been undertaken at Georgia Tech to better understand the physics of the scour process and to be able to directly compare field and laboratory measurements. Comparisons of laboratory and 3D numerical model results in this combined study are given in Liang et al. (2004). The present paper focuses on comparisons of laboratory and field measurements of scour at a bridge over the Chattahoochee River in Georgia.

## 2 Experimental Methods

### 2.1. Laboratory Model Studies

Laboratory experiments were conducted in a 4.3-m wide by 24.4-m long flume with a fixed-bed approach section 7.3 m long and a mobile-bed working section having a length of 7.0 m where the bridge piers and bridge embankments were placed 12.0 m downstream of the flume entrance. The fixed-bed sections were constructed of fiberglass placed over vertical wooden templates cut to match the field measurements of river bathymetry. A layer of uniform fine gravel having a median grain size of 3.3 mm was attached to the fiberglass bed with polyurethane to create fully-rough turbulent flow in the approach fixed-bed section. The initial velocity and turbulence measurements were made for a fixed bed in the vicinity of the model pier bent. This was achieved by spraying polyurethane on the mobile bed to temporarily hold it in place. For subsequent scour experiments, the mobile bed material was replaced with the same sediment having a median grain size of 1.1 mm and a geometric standard deviation of 1.3. No scour occurred upstream of the pier bent because conditions for incipient live-bed scour were not exceeded.

The water supply to the flume was provided from a large constant-head tank through a 0.305-m diameter pipe that can deliver up to 0.30 m<sup>3</sup>/s to the head box of the flume. A flow diffuser, overflow weir, and baffles in the flume head box produced stilling of the inflow and a uniform flume inlet velocity distribution. A flap tailgate controlled the tailwater elevation. Water recirculated through the laboratory sump from which two pumps continuously provided overflow to the constant-head tank. In the supply pipe, discharge was measured by a magnetic flow meter with an uncertainty of  $\pm 0.0003$  m<sup>3</sup>/s.

The central pier bent is shown in Fig. 1 with prototype dimensions. It was constructed to a geometric scale of 1:40 and placed in the full 3D river model which included the entire bridge opening with floodplain as well as main-channel bathymetry up to the 100-yr flood stage. The inner piers are tapered from a width of 1.25 m at bed level to 0.98 m at the 100-yr flood stage. They are the original piers in existence before widening of the bridge occurred. The outer rectangular piers, which have a width of 1.07 m and a length of 1.52 m in the flow direction, were added when the bridge was widened.

An instrument carriage was mounted on horizontal steel rails and was moved along the flume on wheels driven by a cable system and electric motor. Velocities were measured

with a 10 MHz acoustic Doppler velocimeter (ADV) that was attached to the instrument carriage on a mobile point gauge assembly that could be accurately positioned in all three spatial dimensions. The sampling frequency of the ADV was chosen to be 25 Hz with a sampling duration of 2 minutes at each measuring location.

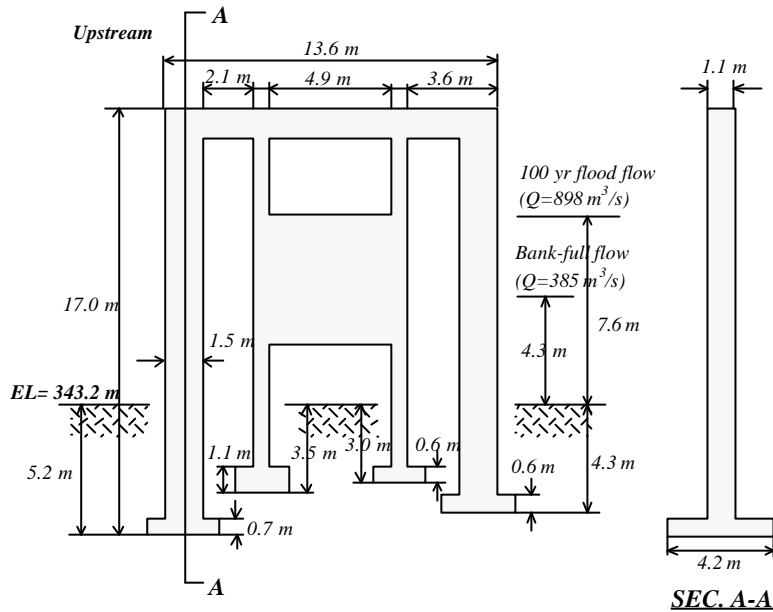

Figure 1. Schematic of central pier bent with prototype elevations and dimensions.

Velocities were measured at relative heights above the bed with respect to the depth of approximately 0.04, 0.1, 0.2, 0.4, and 0.6 throughout the flow field. A detailed vertical profile of the approach velocity was measured including turbulence quantities.

After completion of the flow-field measurements over a fixed bed, the mobile bed was installed in the vicinity of the central pier bent, and scour experiments were conducted. The flume was slowly filled to a depth larger than the test depth so as to prevent scour while the test discharge was set. Then the tailgate was lowered to achieve the desired depth of flow. Measurements of scour depth as a function of time at a fixed point were measured with the ADV to determine when equilibrium had been reached. Then the flow rate was reduced while keeping the scoured bed submerged, and the bed elevations were mapped using the ADV and a point gauge with uncertainty of  $\pm 0.001$  m.

## 2.2. Field Measurements

Fixed field instrumentation has been installed at four bridge sites, which represent various sediment types and physiographic regions in Georgia. The site discussed in this paper is a bridge over the Chattahoochee River in north Georgia in the Piedmont physiographic

province. A U. S. Geological Survey gauging station with 45 years of record is located at the bridge where the drainage area is 816 km<sup>2</sup>. The site has the following equipment:

- stage sensor;
- cross-channel two-dimensional velocity sensor;
- fathometer array to record streambed elevation;
- rain gauge;
- data logger and controller for each device;
- solar panel and instrumentation shelter; and
- satellite telemetry.

The fathometers are attached to the central bridge pier bent in the main channel in order to monitor the changes over time (30-minute intervals) in bed elevation around the bridge piers. One fathometer is located at the nose of the upstream pier and another is positioned on the side of the same pier. Two additional fathometers are located on either side of the most downstream pier of the pier bent. A cross-channel velocity sensor measures two-dimensional velocity in three bins across the channel in the bridge-approach section. The sensor is mounted at a fixed location and aimed across the channel. The velocity meter uses acoustic-Doppler technology and has its own system controller on site. Velocities are recorded at 15-minute intervals.

### 3 Results

Laboratory measurements of scour contours and velocity vectors (before scour) at a relative height above the bed of 0.4 are shown in Fig. 2 for a bank-full flow of 385 m<sup>3</sup>/s that occurred on July 3, 2003. The velocity vectors are nondimensionalized by the approach velocity,  $V_1$ , and the horizontal positions and scour depths are nondimensionalized by the width of the upstream pier,  $b$ . The flood recurrence interval for this event is approximately 2 years. An ellipsoidal scour hole is apparent around the entire pier bent with a localized maximum scour depth just upstream of the nose of the first pier. The approach velocity is skewed at an angle of 4.3° relative to the longitudinal centerline of the pier bent. The velocity vectors show the splitting of the flow around the pier bent, and reduction in magnitude near the piers and in the wake of the piers.

The fathometer measurements of bed elevation with time are shown throughout the hydrograph in Fig. 3. The greatest scour occurs in front of the nose of the upstream pier in agreement with the laboratory results, but there is an obvious infilling of the scour hole on the recession side of the hydrograph after a constant elevation is reached indicating equilibrium live-bed scour. Relatively little scour occurs on the right side of the upstream pier (right front), but measurable scour is apparent around the sides of the most downstream pier (right and left rear). Additional time records of bed elevation show minor scour and fill, typically less than about 0.3 m, for several smaller flows.

Measured channel cross sections just upstream of the bridge for several flow events are compared with the laboratory experiments in Fig. 4. The event of June 13, 2003 was a very small one, but it established the reference bed elevation of 343.2 m prior to the

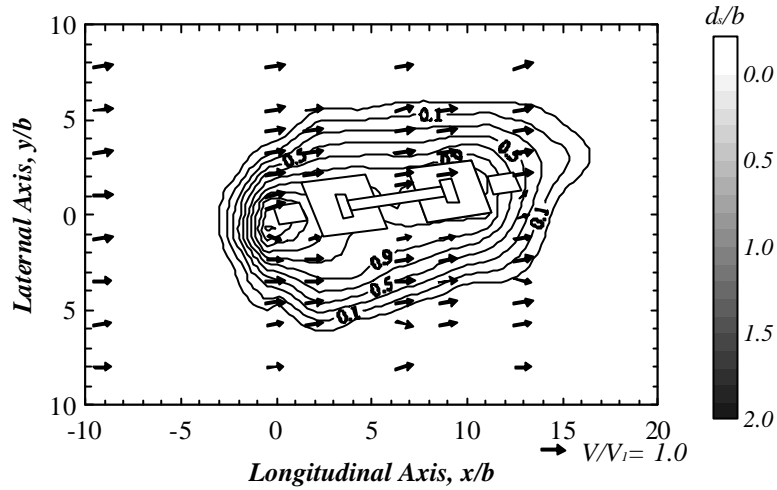

Figure 2. Laboratory scour contours and measured velocity vectors around central pier bent for bank-full flow ( $y_1/b = 4.0$ ,  $Q_{model} = 0.0382 \text{ m}^3/\text{s}$ ).

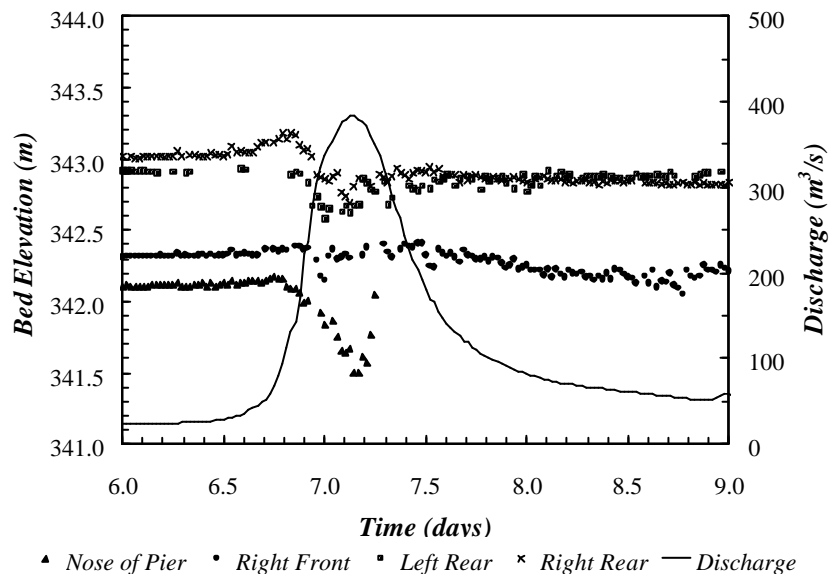

Figure 3. Time history of discharge and bed elevations around central pier bent for bank-full discharge of  $385 \text{ m}^3/\text{s}$  in the field on July 2, 2003 ( $y_1/b = 4.0$ ).

occurrence of the July 2 flood event. There is relatively close agreement between the field cross sections for the events of 1961 and July 2, 2003 which had almost identical discharges. Good agreement is also shown in Fig. 4 between the laboratory cross section

measured after scour and the field cross sections for these two flood events measured near the time of peak discharge. The obvious disagreement is the occurrence of what are apparently dunes to the left of the pier for the live-bed scour in the prototype because the laboratory model measurement was taken for clear-water scour.

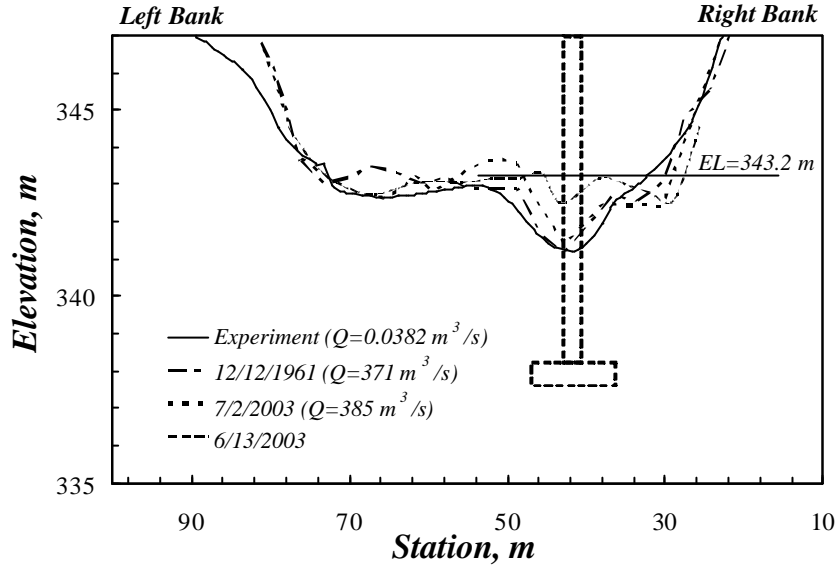

Figure 4. Comparison of scour in prototype and laboratory cross sections just upstream of the bridge looking downstream.

Comparisons between laboratory and field measurements of velocity to the left of the central bridge pier are shown in Fig. 5 for the bank-full event of July 2, 2003. There is close agreement between the laboratory velocities scaled up with Froude number similarity and the field measurements made during the flood with the fixed acoustic Doppler instrument.

#### 4 Scour Modeling and Pier Scour Formulas

Dimensional analysis of the pier scour problem for relatively uniform sediment produces (Ettema et al. 1998, Sturm 2001):

$$\frac{d_s}{b} = f(K_s, K_q, \frac{y_1}{b}, \frac{b}{d_{50}}, \frac{V_1}{V_c}, Fr) \quad (1)$$

in which  $d_s$  = scour depth;  $b$  = pier width;  $K_s$  = shape factor;  $K_q$  = skewness factor;  $y_1$  = approach depth;  $V_1$  = approach velocity;  $V_c$  = critical velocity;  $d_{50}$  = median sediment size; and  $Fr$  = approach Froude number. The 1:40 scale laboratory model was constructed as a Froude-number model with equality of  $y_1/b$  values. The sediment size was selected to be

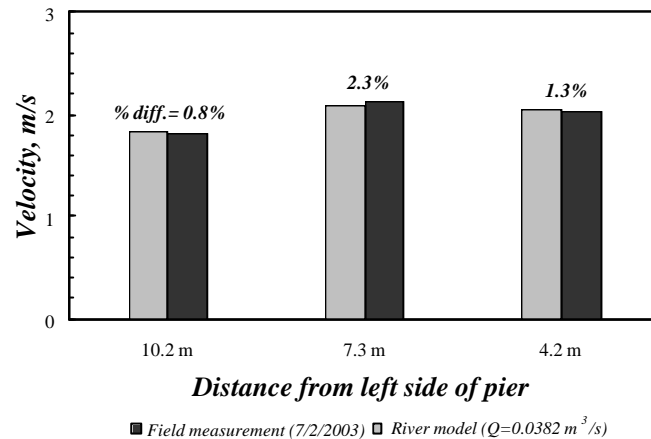

Figure 5. Comparison of field and laboratory velocities measured on the left side of the pier bent during bank-full flood event of July 2, 2003.

1.1 mm to obtain clear-water scour near the maximum of  $V_1/V_c = 1.0$  at approximately the same  $Fr$  as the prototype for the bank-full and the 100-yr flood flows. Approach Froude numbers do not change very much for this range of events. The model sediment size results in a value of  $b/d_{50} = 24.5$  in the laboratory at which several pier scour formulas indicate almost no effect of this parameter on maximum clear-water scour depth.

The dimensionless maximum pier scour depths are shown in Fig. 6 for three laboratory clear-water scour experiments having different values of  $V_1/V_c$ , all less than 1.0 but with constant values of  $y_1/b = 4.0$  in agreement with the bank-full flood event. The values of the Froude number are shown next to each data point. The data point shown in Fig. 6 with a laboratory Froude number of 0.30 is the one that represents the laboratory results that have been compared favorably with field data in all previous figures, and it agrees relatively closely with the field live-bed scour depth shown for the prototype Froude number of 0.33. Also shown in Fig. 6 are the pier scour formulas of Melville (1997) and Sheppard (2003) for clear-water scour in the laboratory with  $b/d_{50} = 24.5$  and  $y_1/b = 4.0$ . There is good agreement between the laboratory data and these two clear-water scour formulas. However, the prototype is in the live-bed scour regime for the bank-full event with  $d_{50} = 0.7$  mm and  $b/d_{50} = 1570$ , which is obviously quite different than the model value. Accordingly, the proposed live-bed scour formula of Sheppard (2003) obtained from scour data in a large flume is compared with the field scour depth in Fig. 6, and the results agree reasonably well considering that Sheppard's formula has been extrapolated beyond the maximum value of  $b/d_{50} = 564$  for his data. His large-flume data suggest that very large values of  $b/d_{50}$  which occur in the field diminish the maximum clear-water scour depth with approximately a straight line drawn by his formula between the reduced maximum clear-water scour depth and the live-bed scour peak at which the bedforms become flat or plane bed.

## 5 Summary

The field and laboratory results in this paper suggest that in some cases modeling of live-bed scour for complex piers might be done in the laboratory in the clear-water regime by preserving Froude number similarity with equality of  $y_1/b$  values and with  $b/d_{50}$  close to 25. The apparent reduction in scour at large values of  $b/d_{50}$  is modeled by  $V_1/V_c < 1.0$  in the laboratory. However, additional continuous field measurements such as those given in this paper are needed to extend the predictive range of live-bed scour formulas obtained from laboratory flume data to much larger values of  $b/d_{50}$  that occur in the field.

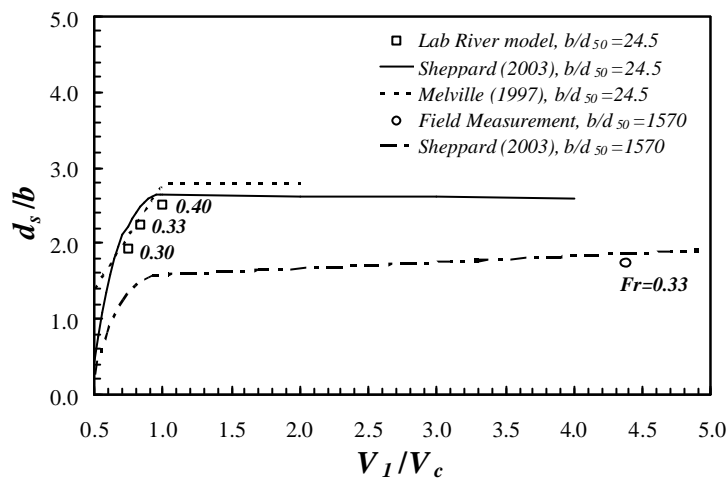

Figure 6. Comparison of laboratory and field measurements of scour depth with formulas.

## Acknowledgments

This research is being funded by the Georgia Department of Transportation.

## References

- Ettema, R., Melville, B. W., and Barkdoll, B. (1998). "Scale Effect in Pier-Scour Experiments." *J. Hyd. Engrg., ASCE*, 124(6), 639-642.
- Landers, M. N. and Mueller, D. S. (1996). "Evaluation of Selected Pier-Scour Equations Using Field Data." *Transp. Res. Record*, National Research Council, Washington, D.C., 186-195.
- Liang, G., Lee, SeungOh, Sotiropoulos, F., and Sturm, T. "3D Unsteady RANS Modeling of Complex Hydraulic Flows. II. Model Validation" Submitted to *J. Hyd. Engrg., ASCE*, 2004.
- Melville, B. W. (1997). "Pier and Abutment Scour: Integrated Approach." *J. Hyd. Engrg., ASCE*, 123(2), 125-136.
- Melville, B. W., and Coleman, S. E. (2000). *Bridge Scour*. Water Resources Publications, Highlands Ranch, Colorado.
- Sheppard, D. Max (2003). "Large Scale and Live Bed Local Pier Scour Experiments." Final Report, Florida Department of Transportation, Tallahassee, BB-473.
- Sturm, T. W. (2001). *Open Channel Hydraulics*. McGraw-Hill, New York.