

# EROSION RATE OF COHESIVE SEDIMENT BY RUNNING WATER

Masato SEKINE<sup>1</sup> and Ken-ichiro NISHIMORI<sup>2</sup>

<sup>1</sup> Member of JSCE, Professor, Dept. of Civil & Environmental Engineering, Waseda University  
(3-4-1, Okubo, Shinjuku, Tokyo 169-8555, Japan)

E-mail: sekine@waseda.jp

<sup>2</sup> Member of JSCE, Research Associate, Dept. of Civil & Environmental Engineering, Waseda University  
(3-4-1, Okubo, Shinjuku, Tokyo 169-8555, Japan)

E-mail: westwood@aoni.waseda.jp

Erosion rate of cohesive sediment was investigated experimentally in this study. The final goal is to derive the erosion rate formula for the naturally deposited cohesive sediment on river beds. In this study, the clay “kaolin” was used, and the test sample of this experiment was composed of clay and silica sand, the containing percentage of each is variable. Water content in sample is another parameter which affects the erosion rate. Extensive series of experiments, the condition of which were set systematically, were conducted in a closed conduit in the experimental apparatus in order to evaluate the effect of each governing parameter on the erosion rate. It was concluded that a frictional velocity of flow and a water temperature are the dominant parameters in practical point of view. Erosion rate formula was derived on the basis of the experimental results, and it was confirmed that it agrees well with the experimental data and the accuracy of it is satisfactory.

**Key Words :** *Erosion rate, cohesive sediment, erosion rate formula, frictional velocity*

## 1. INTRODUCTION

A considerable number of studies on sediment transport in rivers have been conducted for the period more than a half century. Most studies were carried out in order to clarify the sediment transport mechanism of sand or gravel. In case of cohesive sediment such as clay, on the other hand, only a limited number of studies have been made. To the best of the authors' knowledge, the experimental studies by Partheniades<sup>1)</sup>, Ashida and Tanaka<sup>2)</sup>, Murray<sup>3)</sup>, Ariathurai and Arulanandan<sup>4)</sup>, Ohtsubo and Muraoka<sup>5)</sup>, Michiue, Suzuki and Hinokidani<sup>6)</sup>, Briaud et al.<sup>7)</sup> were worthy of note. However, the number of obtained data in each experiment was restricted, and no systematic study in relatively wide range of governing parameters had been conducted. Therefore, there is little information available on the erosion rate of cohesive sediment by running water, and the erosion mechanism of cohesive sediment has not been fully understood yet. This is due to the

complicated mechanism that the cohesive force is exerted on the surface of clay particles to combine each other. From an engineering point of view, a knowledge of how much deposited cohesive sediment can be removed under the force of given shear stress becomes more important recently when we consider a effective management of river structures such as a dam or a sluice gate. The knowledge is also indispensable to discuss about the stable channel geometry of river which is formed mainly by cohesive sediment.

Considering the background mentioned above, the authors have been conducting the experimental studies on the erosion process of soft cohesive sediment which deposits on the channel bed (see in Sekine et al.<sup>8)</sup>). More than 100 of erosion experiments were performed in a closed conduit with a test sample of clay-sand mixture under the systematically arranged conditions. In this study, the test sample was made of kaolin. The purpose of this study was to investigate the effect of some governing

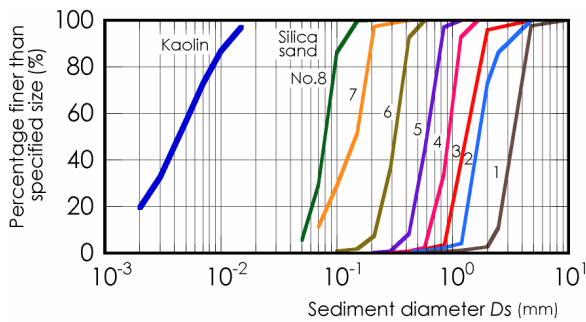

Fig.1 Sediment size distribution.

parameters on the erosion rate of cohesive sediment and to derive the erosion rate formula on the basis of experimental results. It was revealed that the important parameters which affect the erosion rate were the frictional velocity  $u^*$  on a surface of the test sample, a water temperature  $T$ , a clay content ratio  $R_{cc}$ , a water content ratio  $R_{wc}$  and so on. Experimental results indicate that the formula works well, and the predicted values agree well with the experimental data.

## 2. EXPERIMENTAL APPARATUS AND PROCEDURE

In this study, test sample is made of kaolin and silica sand, the size distributions of which are seen in Fig.1. Main series of experiments were conducted for a kaolin sample without any sand. Another series of experiments were also done for the sample containing specific amount of sand. Silica sand No.3 was the standard one, and some other size of sand (see in Fig.1) was also tested in order to investigate the effect of grain size of sand. Important parameters which characterize the test sample of cohesive sediment are as follows: (a) the weight ratio of clay to the total sediment, which is defined as a clay content ratio  $R_{cc}$ , (b) the weight ratio of water to the clay, which is defined as a water content ratio  $R_{wc}$ , (c) the grain size of sand  $D_s$ , and (d) a water temperature  $T$ . In this study, the clay content ratio  $R_{cc}$  was set between 0.6 and 1.0, the water content ratio  $R_{wc}$  between 0.6 and 0.8, and the water temperature between 4 and 26 degrees centigrade. In preparing the test sample, sand, clay and water were put together in a ball mill under the specified ratio, and were mixed mechanically until the sample became uniform. After completing this procedure, the sample was set in the bottom trench of the conduit without being disturbed, and was left there under a still water for half a day in order to allow for consolidation.

In Fig.2, the outline of the experimental

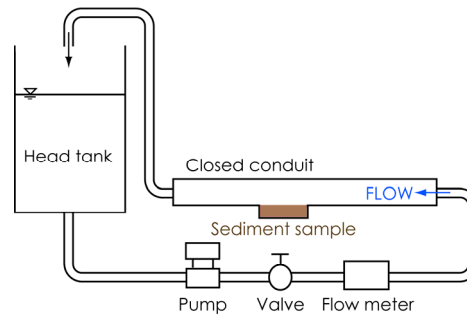
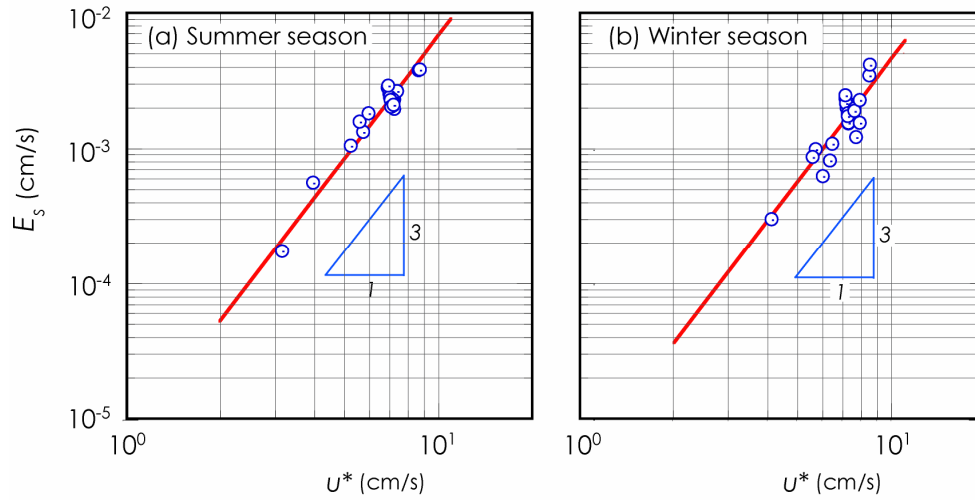

Fig.2 Outline of the experimental apparatus.

apparatus is shown. Experiments were conducted in a circulating closed conduit system with a square cross-section. The conduit is 500 cm long, 10 cm wide and 10 cm deep, and is made of acrylic board, so that one can observe the surface state of the sample and the phenomenon which occurs in the conduit. The test sample was placed in the bottom trench which was located 250 to 300 cm from the inlet of the conduit. The size of the sample is 50 cm long, 10 cm wide and 5 cm deep. On the ceiling and the bottom of the rest of the conduit, a rubber board with dense pyramid-like roughness elements, the height of which are 3 mm, is attached so as to make the boundary layer fully developed before the flow reaches the test sample. The hydraulic conditions of the flow in this conduit are controlled only by operating the flow valve. As a preliminary experiment, the flow measurement by Laser-Doppler anemometer was conducted. It was found from this measurement that the boundary layer was fully developed and the fully-developed turbulent shear flow was established at least in the reach of test sample. And then a frictional resistance coefficient  $f$  of the flow was evaluated to be almost 0.011. Therefore, the averaged shear stress  $\tau_o$  exerted on the surface of test sample could be evaluated approximately by the relation  $\tau_o = \rho f U^2$ , where  $U$  is an average flow velocity in the experimental conduit. After finishing the preparation of sample, the water flow was introduced over the test sample for ten minutes. And then the water flow was stopped temporarily. After that, the surface elevation of the sample was measured directly by using a Laser Displacement Sensor. Measurements were done along the longitudinal measuring lines on the surface which were set at equal intervals of 1 cm from the side wall of conduit, and the number of points on each line was 120. So the total number of measuring points was 1080. Furthermore, the data were transferred as digital data into a computer after A to D conversion, and were processed statistically. The volume of sample which was eroded during a given period was evaluated by summing up the product of



**Fig.3** Relationship between the frictional velocity and the erosion rate.

local erosion depth and its projected area over the surface. Erosion rate  $E_s$  is defined as the averaged value of eroded depth divided by the time. In this study, the period of 10 minutes was set as a general rule. And the effect of the period on erosion rate was also investigated. As a result, it was confirmed that the erosion rate was not affected by the period under the condition of this study. But if we try to measure the erosion rate under the condition of flow velocity much higher than that in present study, the mechanics which enable the surface elevation of test sample be kept constant must be needed in the experimental apparatus. It should be noted that the side wall region where the velocity is slightly smaller than the other region is excluded from measuring points. Photographs and video images were also taken to analyze the surface state and erosion process more precisely at a later date. Several series of experiments were conducted all the year round, the data of which were processed by classifying them into the following two categories: (a) the summer season in which a water temperature was between 18 and 22 degrees centigrade (higher temperature), and (b) the winter season in which a temperature between 9 and 12 degrees centigrade (lower temperature). The functional relationship between a water temperature and the erosion rate was also investigated in this paper.

### 3. EFFECT OF SOME GOVERNING PARAMETERS ON EROSION RATE

The relationship between the erosion rate and each of the governing parameters is discussed here on the basis of more than 100 experimental results. The parameters to be noted are (a) a frictional velocity  $u^*$

exerted on the surface of test sample, (b) a clay content ratio  $R_{cc}$ , (c) a water content ratio  $R_{wc}$ , (d) a grain size of sand or gravel  $D_s$ , (e) a water temperature  $T$ .

First of all, the relationship between the erosion rate  $E_s$  and the frictional velocity  $u^*$  is seen in **Fig.3**. In this figure, the data obtained under the condition that  $R_{cc} = 1$  and  $R_{wc} = 0.75$  were plotted. The most important and dominant parameter is the shear stress or the frictional velocity which is exerted on the surface of sediment sample. In this figure, the experimental data were processed by classifying them into two categories of water temperature. In case of our experimental apparatus, it was impossible to regulate the water temperature. So the data obtained under the condition of water temperature between 18 and 22 degrees centigrade were plotted in the left of Figure 3 as a summer season, and the data obtained between 8 and 12 degrees centigrade were in the right of it as a winter season. We can see that the erosion rate is larger as the water temperature grows higher. This tendency will be discussed in detail later. In this figure, the solid line corresponds to a following relation;

$$E_s = \Theta \cdot u^{*3} \quad (1)$$

in which  $\Theta$  is a coefficient and is possible to depend on the water temperature, the water content ratio and so on. It is obvious that the experimental data agrees well with this relation although there are some errors due to the variation of the water temperature. We can conclude that the erosion rate is proportional to the third power of frictional velocity.

**Fig.4(a)** shows the relationship between the erosion rate  $E_s$  and the clay content ratio  $R_{cc}$ . In this figure, the data obtained under the condition that  $u^* = 7.59$  (cm/s) and  $R_{wc} = 0.75$  were plotted. And the relationship between the erosion rate and the grain

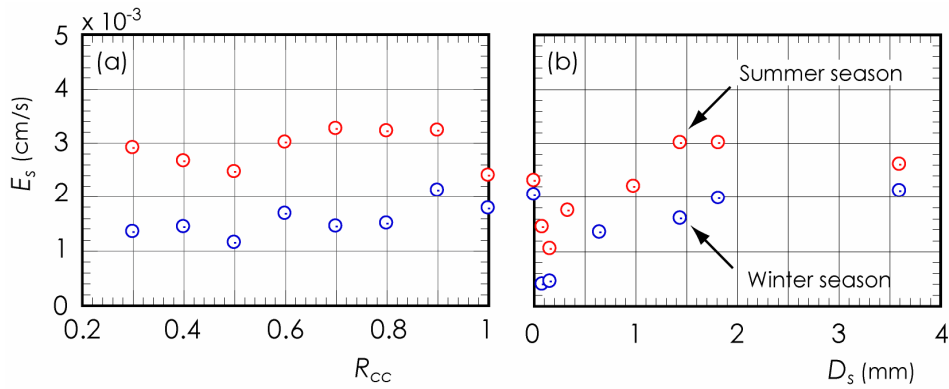

Fig.4 Relationship between the clay content ratio or the grain size of sand and the erosion rate.

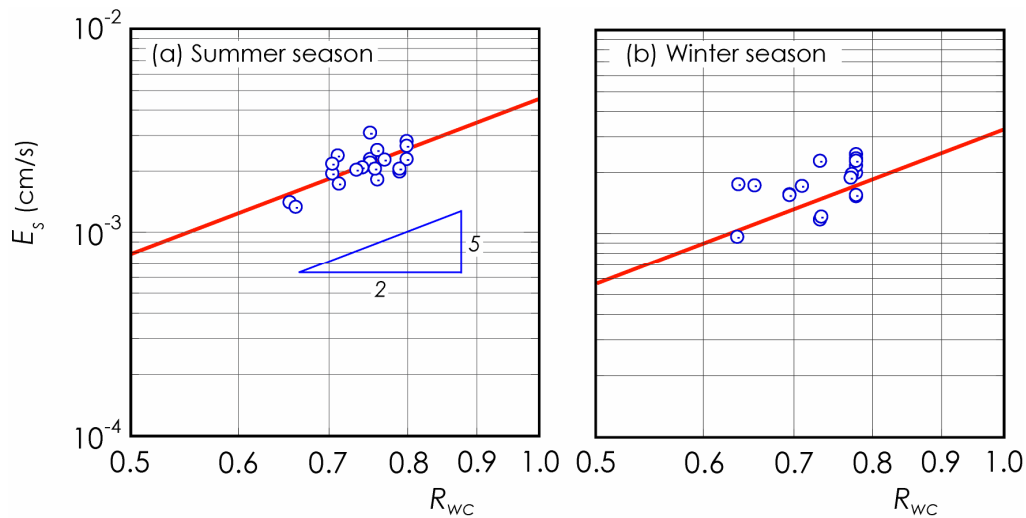

Fig.5 Relationship between the water content ratio and the erosion rate.

size of sand or gravel  $D_s$  is also seen in Fig.4(b). In this figure, the data obtained under the condition that  $u^* = 7.59$  (cm/s),  $R_{wc} = 0.75$  and  $R_{cc} = 0.8$  were plotted. We can understand that the effect of these two parameters  $R_{cc}$  and  $D_s$  on the erosion rate  $E_s$  is not so significant that we may assume  $E_s$  not to vary with these parameters. This means that the proportional constant  $\Theta$  is independent of  $R_{cc}$  and  $D_s$ .

Fig.5 shows the relationship between the erosion rate and the water content ratio  $R_{wc}$ . Experimental conditions for the data was set that  $u^* = 7.59$  (cm/s) and  $R_{cc} = 1.0$ . In such a condition, the value of  $R_{wc}$  is equivalent to that of water content. The liquid limit of this clay 'kaolin' is 0.511. The solid line in this figure corresponds to the relationship that  $E_s$  is proportional to the 2.5 power of the water content ratio. The experimental data show fairly good agreement with the solid line. This means that the coefficient  $\Theta$  in Eq. (1) depends on  $R_{wc}^{2.5}$ . In the range of water content close to the liquid limit, on the other hand, we have confirmed that  $E_s$  takes a different tendency from the solid line. According to the wide range of experiments, no erosion was

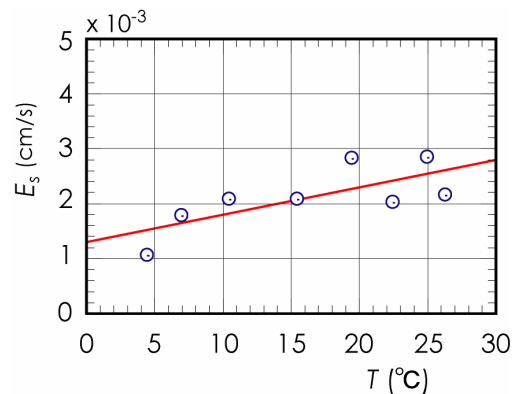

Fig.6 Relationship between the water temperature and the erosion rate.

observed at the water content less than the liquid limit. So there exists a critical condition for erosion in the view point of water content. In this study, we tried to investigate the influence of  $R_{wc}$  on the erosion rate in the range of  $R_{wc}$  much higher than the liquid limit. But if we consider the erosion phenomenon of naturally deposited and consolidated cohesive sediment on river bed, the relationship just like the

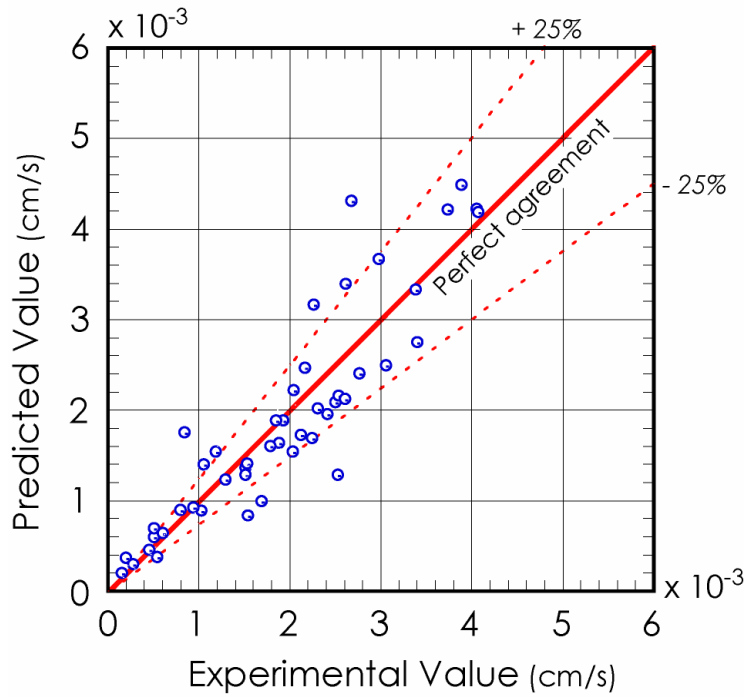

Fig.7 Direct comparison between the measured value of erosion rate and the predicted one by the derived formula.

one in Fig.6 may be less significant. For reference, we conducted further experimental study to investigate the erosion process of cohesive sediment which was sampled from the Rokkaku River, Japan (Nishimori and Sekine et al.<sup>9</sup>). It was confirmed that the water content or the parameter  $R_{wc}$  of the sample varies temporally and spatially only in a narrow range. In such experiments, we can treat  $R_{wc}$  as a constant value.

In Figs.3, 4 and 5, the experimental data were plotted in two different figures according to the range of water temperature  $T$ . Now we discuss the dependence of the erosion rate on the water temperature. Fig.6 shows the relationship between them. The data in this figure was obtained under the condition that  $u^* = 7.59$  (cm/s),  $R_{wc} = 0.75$  and  $R_{cc} = 1$ . One can see that  $E_s$  is proportional to the water temperature  $T$ . This means that the coefficient  $\Theta$  in Eq. (1) is linearly proportional to  $T$ .

#### 4. EROSION RATE FORMULA

Erosion rate formula of cohesive sediment is discussed here on the basis of the experimental results shown before. The standard expression of it was shown by Eq. (1). And it was found on the basis of the results explained before that the coefficient  $\Theta$  in Eq. (1) is formulated as follows;

$$\Theta = \alpha(T) \cdot R_{wc}^{2.5}, \quad \alpha(T) = k_1 T + k_2 \quad (2)$$

in which the coefficients  $k_1$  and  $k_2$  have a dimension

of  $[L T^{-1}]^{-2}$ , and following values were obtained for kaolin in cm-sec unit as follows;  $k_1 = 3.3 \times 10^{-7}$ ,  $k_2 = 5.8 \times 10^{-6}$ . In Fig.7, the direct comparison was made between an experimental value and the predicted value by Equations (1) and (2). In this figure, the experimental data which were obtained under the condition of  $R_{cc} = 1$  were plotted, and there exist about 50 data which were not used directly in deriving the relation of Eq. (1). The solid line in this figure expresses a perfect agreement between them, and the data precisely on this line mean no error. The data in the area between two dotted lines correspond to the fact that the errors were restricted within 25%. It is obvious from Fig.7 that the derived erosion rate formula agrees well with the experimental results and the accuracy of it is satisfactory.

Recently some practical investigations were conducted in real rivers, and the formula of Eq. (1) has been tested (Yokoyama et al.<sup>10</sup>; Nishimori and Sekine et al.<sup>9</sup>). According to their investigation, Eq. (1) is valid for the data measured in Japanese rivers at present.

#### 6. CONCLUSION

In this study, the erosion rate of cohesive sediment was investigated experimentally. Governing parameters were specified and the effects of them on the erosion rate  $E_s$  were evaluated. Followings are worthy of remarks obtained in this study; (1)  $E_s$  is proportional to the third power of

frictional velocity, (2)  $E_s$  is weakly dependent on the water temperature and is linearly proportional to it, (3) the amount of containing sand or gravel and its grain size are of no significance, (4)  $E_s$  is proportional to the 2.5 power of the water content ratio, but this tendency seems not to be so important from a practical point of view when we try to derive the erosion rate formula for naturally deposited cohesive sediment on a river bed. The erosion rate formula was derived for kaolin on the basis of experimental results, and the validity of it could be verified.

**ACKNOWLEDGMENT:** This research was conducted under the financial support of Grant-in-Aid for Scientific Research, the Ministry of Education, Science and Culture of Japan (No. 12650521, 14550516 and 17560463). The authors would like to thank Toshihiko Kumai, Nobuaki Iizuka, Kenta Fujio, Yasuhiro Katagiri, Fumihiro Ando, Takayoshi Higuchi and Toshio Akagi for their research assistances.

## REFERENCES

- 1) Partheniades, E. : Erosion and deposition of cohesive soils, Journal of Hydraulic Division, Proc. of ASCE, Vol.91, HY1, pp.105-139, 1965.
- 2) Ashida, K. and Tanaka, K. : Erosion and sediment transport mechanism on the sandy bed with some clay content, Annual Research Report, Prevention Research Institute, Kyoto University, Vol.17B, pp.571-584, 1974 (in Japanese).
- 3) Murray, W. A.: Erodibility of coarse sand-clayey silt mixture, Journal of Hydraulic Division, Proc. of ASCE, Vol.103, HY10, pp.1222-1227, 1977.
- 4) Ariathurai, R. and Arulanandan, K.: Erosion rates of cohesive soils, Journal of Hydraulic Division, Proc. of ASCE, Vol.104, HY2, pp.279-283, 1978.
- 5) Ohtsubo, K. and Muraoka, K.: Physical properties and critical shear stress of cohesive bottom sediments, Proc. of JSCE, pp.225-234, 1985 (in Japanese).
- 6) Michiue, M., Suzuki, K. and Hinokidani, O. : Erosion rate of the cohesive material due to the flow, Reports of the Faculty of Engineering, Tottori University, Vol.17, No.1, pp.93-100, 1986 (in Japanese).
- 7) Briaud, J.L., Ting, F.C.K., Chen, H.C., Gudavalli, R., Perugu, S. and Wei, G. : SRICOS: Prediction of scour rate in cohesive soils at bridge piers, Journal of Geotechnical and Geoenvironmental Engineering, ASCE, Vol.125, No.4, pp.237-246, 1999.
- 8) Sekine, M., Nishimori, K., Fujio K. and Katagiri, Y. : Erosion process of cohesive sediment and erosion rate formula, Journal of Hydroscience and Hydraulic Engineering, JSCE, Vol. 22, No. 1, pp.63-70, 2004.
- 9) Nishimori, K., Sekine, M, Higuchi, T. and Akagi, T. : Experimental study on the erosion rate of naturally deposited cohesive sediment on river beds, Annual Journal of Hydraulic Engineering, JSCE, Vol.52, pp.541-546, 2008 (in Japanese).
- 10) Yokoyama, K., Kaneko, Y. and Takashima, S.: Erosion process of cohesive sediment in an estuarine channel, Annual Journal of Hydraulic Engineering, JSCE, Vol.51, pp.877-882, 2007 (in Japanese).